

260060

FOOT PUMP HYDRAULIC LIFT TABLES

- Capacity ranges from 200 to 6,000 lbs.
- Solid steel top and base construction.
- Floor locks are standard on all 500 lb.+ capacity tables.
- Casters provide easy mobility

STANDARD DUTY TABLES

- LT-02-1616 has four 3" polyolefin swivel casters.
- LT-02-1616 ships via UPS knocked down.
- LT-05/LT-10 models feature 2 rigid and 2 swivel 4" phenolic resin roller bearing casters.
- 7 gauge steel top and base.
- 3/8" lift per stroke.

P/N **260060**

Model: **LT-05-1818**

Capacity: **500#**

Weight: **122 lbs**

Table Size: **18" x 18"**

Lowered Height: **30.5"**

Raised Height: **47.5"**

Support Posts: **Two**

Caster Size: **4"**

REPLACEMENT PARTS LIST

1	270260	KIT: JACK, LT-02/LT-05
2	050734	KIT: FOOT PEDAL ASS'Y (9")
3	050740	KIT: RELIEF HANDLE ASS'Y (9")
4	050754	KIT: PUMPING RELEASE VALVE
* 5	052722	KIT: SEAL KIT
	270233	KIT: SEAL KIT (Prior 3/97)
6	108316	PEDAL RETURN SPRING
7	150001	FLOOR LOCK

* NOT SHOWN

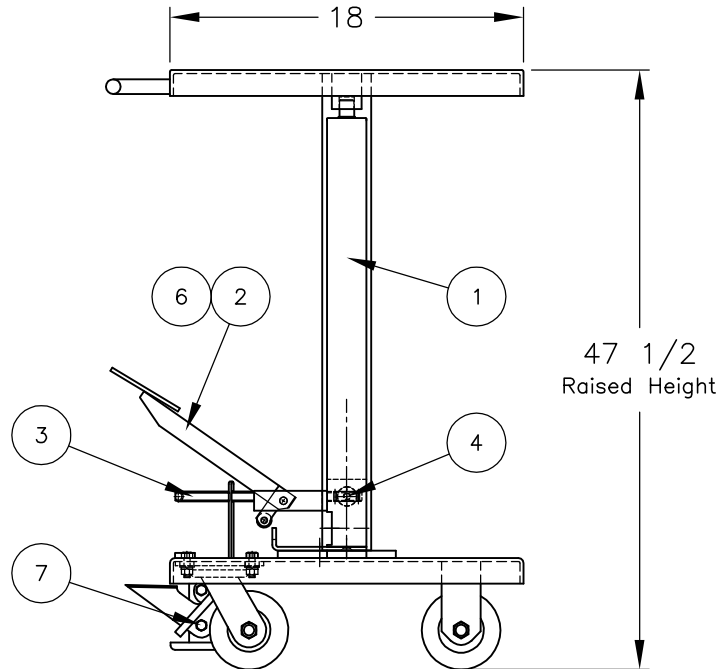

THIS DRAWING IN ALL PARTICULARS IS WESCO INDUSTRIAL PRODUCTS INC. PROPERTY. ALL RIGHTS OF DESIGN, INVENTION OR USE OF ARE RESERVED.

PRINT ISSUED

OCT 23, 2006

WESCO MANUFACTURING
ENGINEERING DEPARTMENT

APP	WESCO INDUSTRIAL PRODUCTS INC.	
	LANSDALE	PENNA. 19446
ECN & DATE	PART NAME	DRAWN: PS 1-21-99
	LT-05-1818	CHECKED:
	TOLERANCE UNLESS OTHERWISE SPECIFIED	APP. ENGR.
	SCALE: 1" = 10"	
REV.	FRACTION 3 PLACE DECIMAL 2 PLACE DECIMAL	
	± 1/64 ± .005 ± .01	
	ANGULAR ± 1-1/2' SHEET 1 OF 1	A - 260060 REV
BREAK ALL SHARP EDGES AND REMOVE ALL BURRS		