

# WESCO ADVANTAGE PRO-POWER Pallet Truck with Lithium Battery

- Operation Manual
- Parts Catalogue

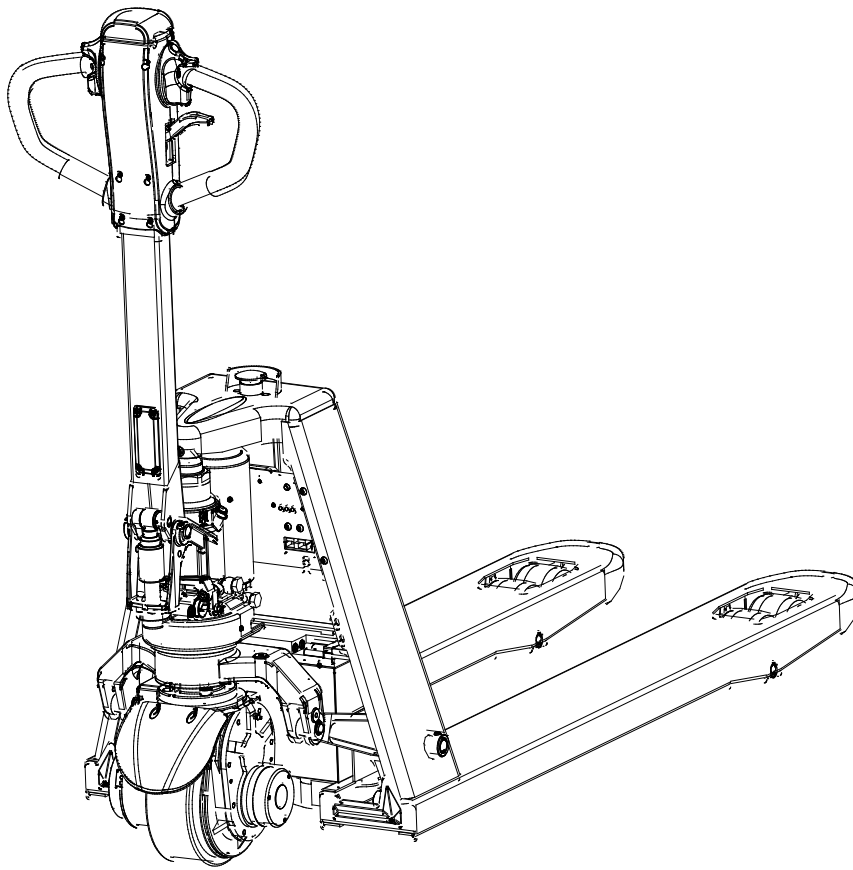

WESCO INDUSTRIAL PRODUCTS, LLC

# Welcome to choose **Wesco** electric pallet truck!

Hope our trucks will provide great convenience

for your work!

- Please read the manual carefully before starting the truck.
- This operation manual is general, and the right to make any technical modifications to the tractors are reserved. Contents provided in this manual for reference only and if wrong in real, prevail in kind.

---

## Content

1. Safety regulations .....	3
2. Allowed environment for using .....	5
3. Technical parameters .....	6
4. Handle installment .....	7
5. Operation .....	8
6. Charge and battery replacement .....	10
7. Maintenance .....	12
8. Truck hoisting .....	14
9. Trouble shooting .....	15
10. Waste treatment .....	15
11. Accessories and spare parts .....	15
12. Electrical schematic diagram .....	16
13. Packing list .....	16

## 1. Safety regulations



Safety shoes are always required to handle the pallet truck.



Safety glasses are recommended to avoid personal accidents while assembling or disassembling the pallet truck.



### **CAUTION!**

When the truck is damaged or has safety problems, stop using it immediately.



### **CAUTION!**

The pallet truck is designed for hard and flat floor only.

It's forbidden to use the truck when :

- the air contains dust or flammable and explosive gases that can cause fire or explosion.
- in freezer or some low temperature, salty or other corrosive environment.
- Rainy outdoor.
- Operate on gravel or grassland.
- the gradient of the ground is greater than the gradient of product design.



### **CAUTION!**

- Careful judgment and responsible attitude should be taken in the operation of pallet trucks.
- The pallet truck is not able to be operated with oily hands or shoes
- Operators shall not wear loose clothes or jewelry



### **CAUTION!**

- When operating the pallet truck, it is necessary to ensure that the ground has sufficient load bearing capacity, where the load is the sum of the weight of the pallet truck and the load.
- Special care should be taken if there are prominent objects that can cause personal injury
- Personnel are prohibited around the operating area of the pallet truck, which may cause personal injury, for example, when the goods fall.

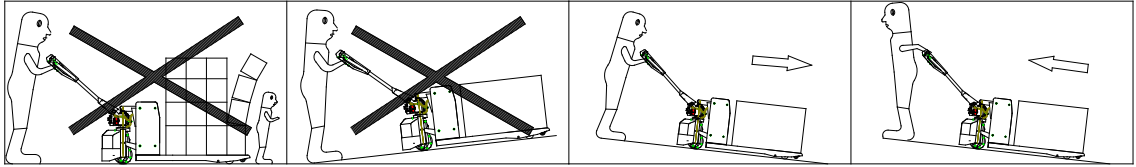

**CAUTION!**

Operators must be very carefully when handling the pallet truck on a slope. See the drawing, the operator should stand ahead of the truck. Operators must be very carefully when handling the pallet truck on a slope. See the drawing, the operator should stand ahead of the truck. When a vehicle runs on a ramp, the driving wheel can be quickly turned to the maximum angle to avoid the risk that the vehicle will continue to slide. This method allows operation only in emergencies.



**WARNING!**

- Avoid high-speed operation when turning to avoid the danger of overturning.
- The goods should not be too high to block sight.
- Brake gently and carefully to avoid cargo slipping off the pallet and causing material damage.
- The pallet truck is not allowed to turn on the slope.
- Before pushing the pallet into the elevator, the operator must ensure that the elevator can withstand the total load of the pallet and cargo, the total weight of the operator and other personnel on the elevator. Make sure the load goes into the elevator first, then the operator. The elevator should keep empty when the pallet truck with load is about to go in/out of it.



**CAUTION!**

- The load shall not exceed the rated load of the vehicle.
  - When stacking goods, the goods should not be too high to avoid the danger of falling down or overturning the pallet truck during handling.
  - It's forbidden to ride people with the pallet truck.
- Keep clear of the pallet truck's working area, avoiding personal injuries due to sudden accidents happened over its working.
- Standing and sitting on the pallet truck is strictly forbidden.

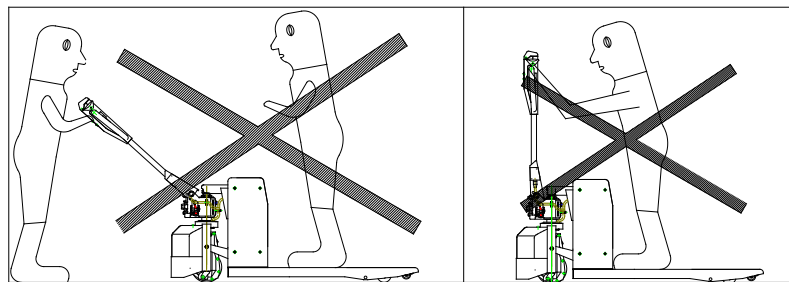

**CAUTION!**

- Keep the fork at the lowest position while it's parked.
- Don't leave the truck on a slope.
- Don't leave the truck at the emergency access.
- Don't leave the pallet truck to block the traffic or affect work.
- Don't use the pallet truck in rain.
- Turn off the power when the pallet truck is unattended.

**2. Allowed environment for using**

This truck is designed to work only on hard and flat floor, indoor. It's not allowed to work in an environment beyond the regulations.

- Ambient temperature shall not be higher than +40°C and no lower than -10°C;
- Hard and flat ground;
- It is prohibited to use in a flammable, explosive or corrosive environment with acid and alkali;

### 3. Technical parameters

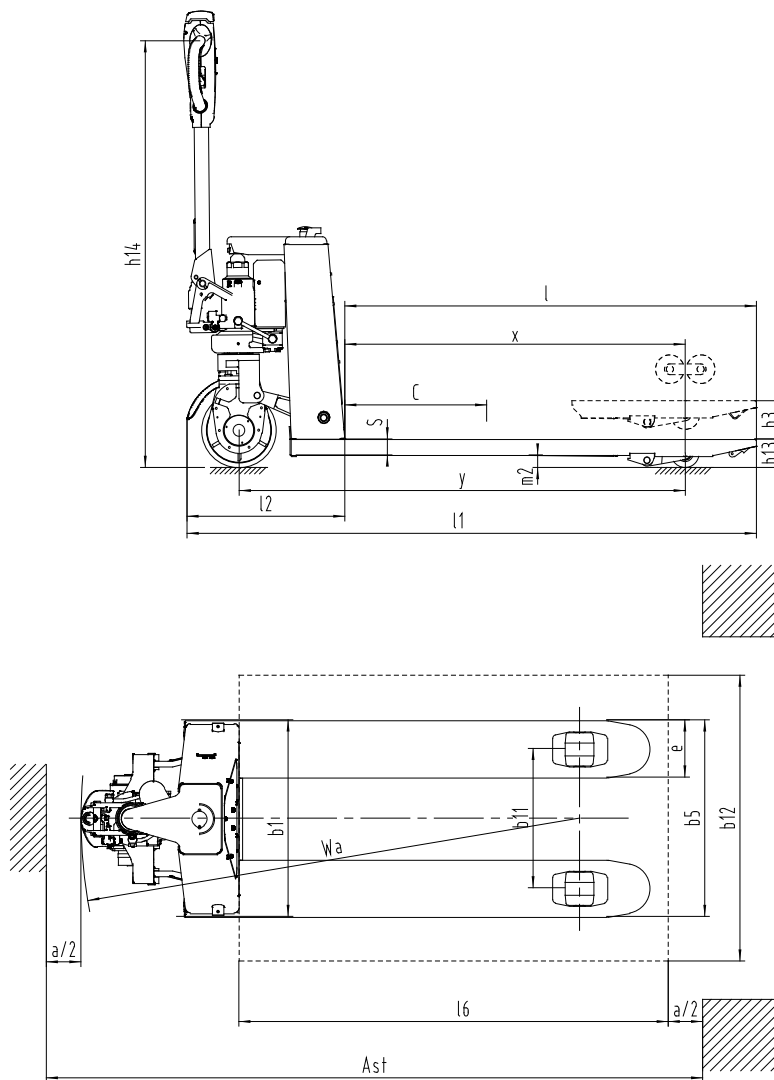

Figure 1

Model		CBD15
Way of driving		Electric
Drive type		Walkie
Load capacity	Q(kg)	1500
Load center distance	C (mm)	600
Fork height,lowered	$h_{13}$ (mm)	80
Tread	Y(mm)	1236/1306
Wheel type		PU
Tyre size, front	mm	$\Phi 210 \times 70$
Tyre size, rear	mm	$\Phi 80$
Wheel number, front/rear (x = driving wheel)		1X/2 (4)
Lift height	$h_3$ (mm)	110
Height of tiller in drive position min./max.	$h_{14}$ (mm)	635/1200

Overall length	$l_1$ (mm)	1580/1650
Length to face of forks	$l_2$ (mm)	430
Overall width	$b_1$ (mm)	550/685
Fork dimensions	s/e/l(mm)	53/160/1150(1220)
Width overall forks	$b_5$ (mm)	550/685
Wheelbase ground distance	$h_1$ (mm)	27
isle width for pallets 1000x1200 crossways	Ast(mm)	2180/2250
Aisle width for pallets 800x1200 lengthways	Ast(mm)	2050/2085
Turning radius	$Wa$ (mm)	1380/1450
Travel speed, laden/unladen	Km/h	4.3/4.5
Max. gradeability, laden/unladen	%	5/20
Driving motor power	KW	0.75
Lifting motor power	KW	0.5
Battery voltage/rated capacity	V/Ah	24/20 ( 30 )
Traveling brake		electric
Noise level at operator's ear, according to DIN12053	dB(A)	70
Service weight(with battery)	Kg	114

#### 4. Handle installment

The handle is removed before shipment in the consideration of the requirement of packing and the safety over transportation, and the steps to install the hand are list as following:

- 4.1 Refer to Figure 1, remove the pin 1 from pin 2, then pull out the pin 2.
- 4.2 Refer to Figure 2, Loose the screw 3, remove the cover plate 4 from handle assembly 5.
- 4.3 Refer to Figure 3, 4, Insert handle assembly 5 (Fig. 2) into A (Fig. 1), connect handle assembly 5 to pump body 10 by pin 2. Thread the rod chain 8 through the hole of pin 2. Pull the handle to horizontal position, take out pin 9 and save it for next time use. Connect the wire of handle assembly 5 to the truck body through connector 6, tighten it with a harness for a reliable connection (see Fig.5). After that, fix it to handle assembly 5 by line card 7 according to Fig. 4.

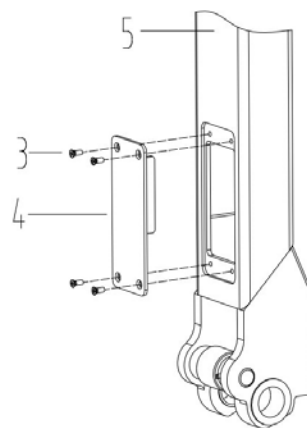
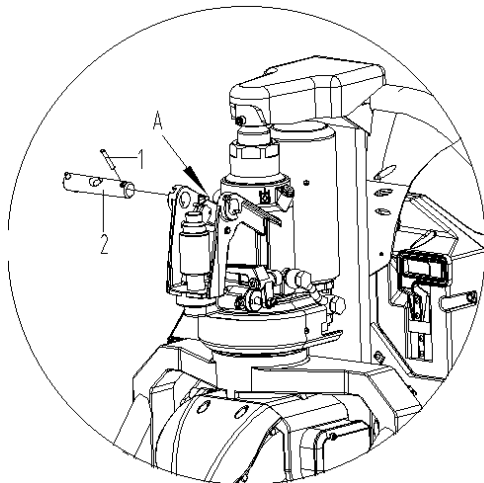

Figure 1

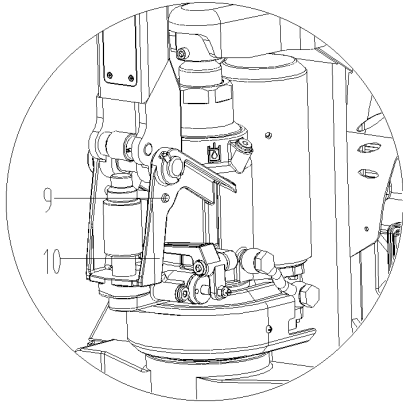

Figure 2

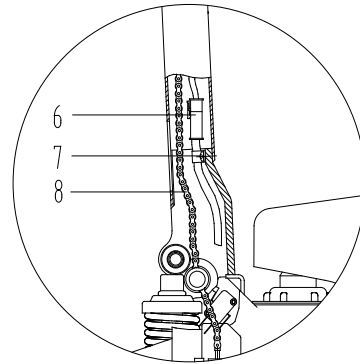

Figure 3

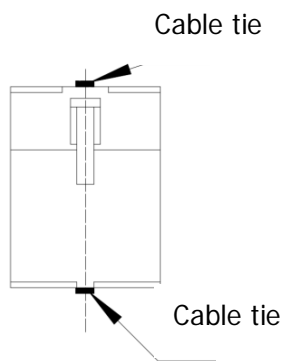

Figure 5

Figure 4

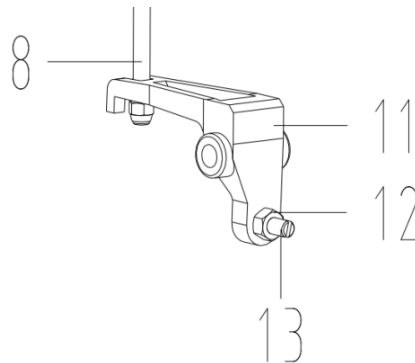

Figure 6

4.4 Refer to Figure 4、6, fix the screw and nut at the end of chain 8 into the groove of lever plate 11

4.5 Pass the pin 2 through pin 2 and fix, install the cover plate 4 onto handle assembly 5.

## 5. Operation

### Vehicle electrified

- Turn on the emergency stop button.

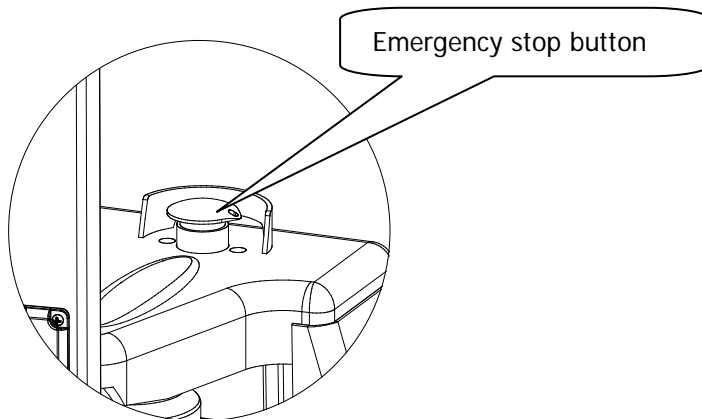

Figure 7



### Fork's lifting and lowering

- Lifting: Press the lifting button to lift
- Lowering: Press the lowering knob to lower

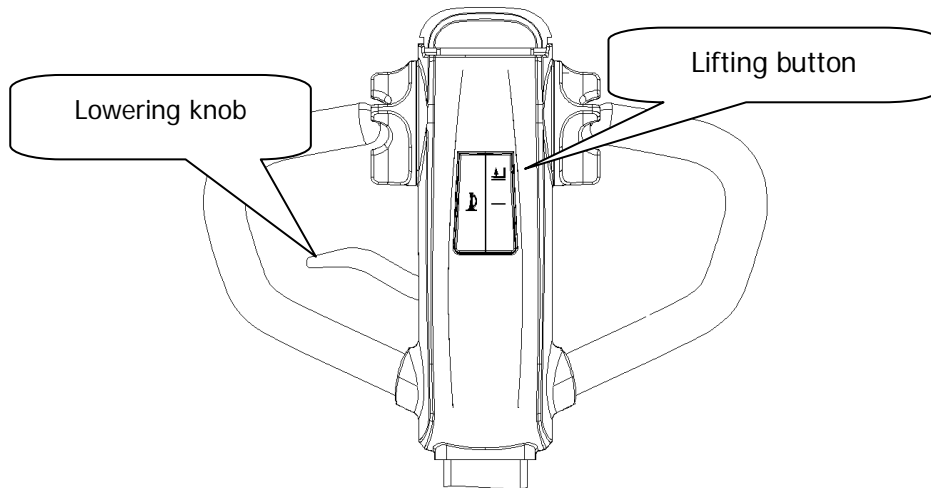

Figure 4

### Traveling of the pallet truck

Rotate the handle to the traveling section,  
A and C are breaking section.  
B is the traveling section

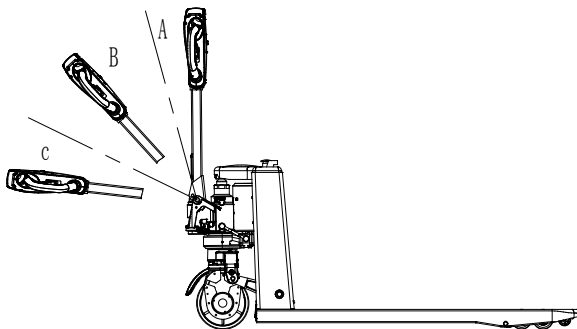

Figure 5

- Rotate the accelerator to start the truck slowly (for safety's reason, no rapid acceleration).

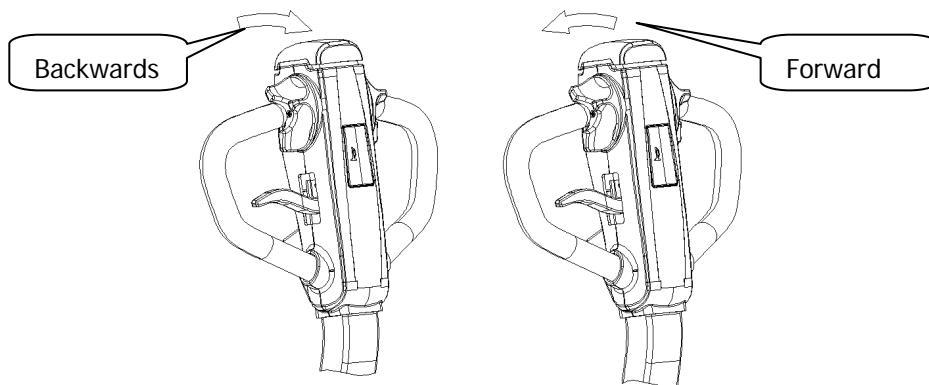

Figure 6

### Parking

- Release the accelerator for normal braking, the truck stops slowly by the regenerative brake of the motor until the brake lock the wheels.
- Turn the handle to A or C quickly for emergency braking(Figure 5), the brake will lock the wheel to achieve an emergency braking.

### Emergency reverse button

The emergency reverse button is at the end of the hand. When it's touched , the truck will stop traveling immediately, then travel backwards for a distance. The function is set to minimize possible squeeze injuries when the truck encounters into obstacles over its traveling.

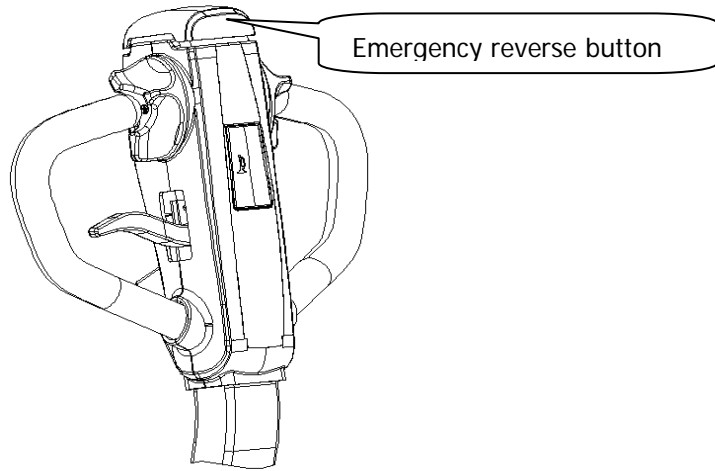

### Safe parking

- Release speed control button to stop the truck.
- Lower the fork to the lowest position.
- Turn off the key switch.
- Disconnect the battery harness in order to park for a long time

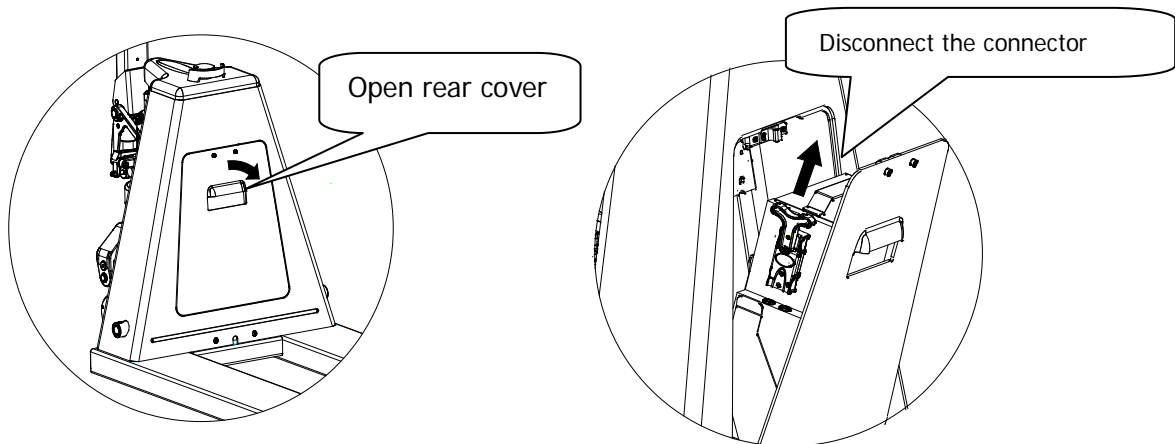

## 6. Charge and battery replacement

### 6.1 Types of battery and use precautions

- 6.1.1 The battery used in this pallet truck is 24V lithium-ion, which is environmental friendly, without chemical mercury and cadmium.

### 6.1.2 Precautions

- ◆ Working ambient temperature of lithium battery is -10 ~ 45°C.
- ◆ Charge and discharge the battery every 3 months when it's stored for a long time.
- ◆ Fully charge the battery before the first use or re-use after long-term idleness.
- ◆ Do not short circuit the battery, which may permanently damage it.
- ◆ Do not weld the battery by yourself.
- ◆ Do not keep the battery in an unfavorable environment, such as extreme temperature, deep cycle, or often overcharge or over-discharge.
- ◆ Do not touch the hot battery until it cools down.
- ◆ Taking down the battery by holding the plug, instead of pulling the charging line.
- ◆ The battery may be hot after charging, cool it down in a ventilated environment.
- ◆ Do not put batteries in water or sea water;
- ◆ Do not try to separate, squeeze, or hit the battery. Battery lye is harmful to skin and eyes, and will corrode clothes.
- ◆ Keep the battery out of children's reach.

### 6.2 Fast battery replacement

- ◆ Shut off the Emer. stop switch
  - ◆ Open the rear cover plate
  - ◆ Separate the power connector properly (**Note: Must hold the puller, but not the wiring while doing this.**)
  - ◆ Connect output end of the charger with the battery
  - ◆ Connect input end to external power supply.
- Red light on the charger on, indicates charging.  
-Green light on, indicates charging completed.

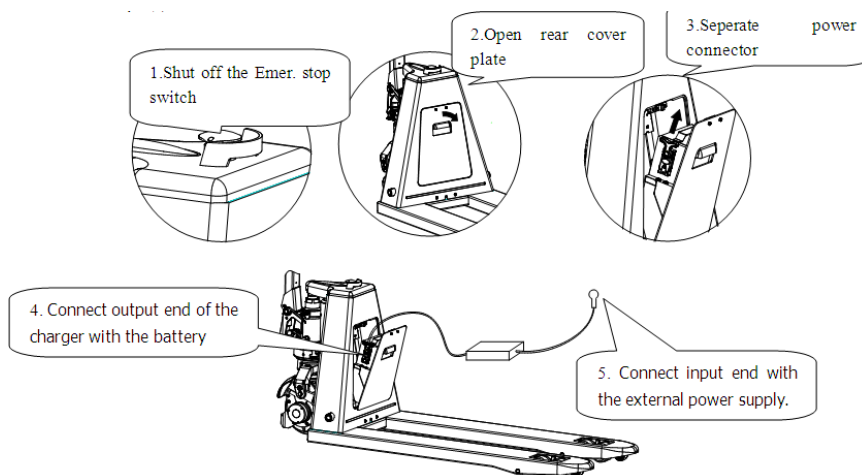

### 6.3 Battery replacement

- ◆ Shut off the Emer. stop switch
- ◆ Open the rear cover plate
- ◆ Separate the power connector properly (**Note: Must hold the puller, but not the wiring while doing this.**)
- ◆ Pull out the battery

- ◆ Install the battery in the reverse order of removal

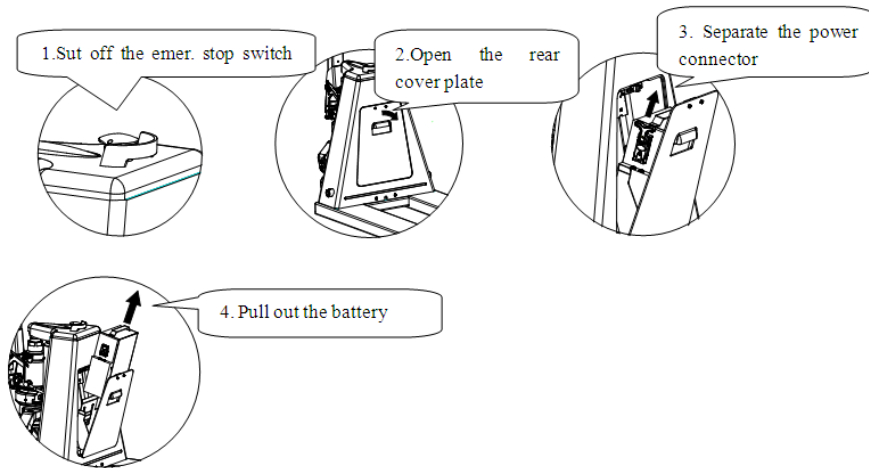

#### 6.4 Precautions on battery charging

- Must use the special Li-ion charger of our company; working voltage of charger is 24V; maximum charging voltage is 29.4V, charging current is 6A.
- Do not reversely charge the battery,
- Stop charging immediately if the battery is found abnormal hot during charging, recharge after cooling down naturally.
- Must hold the puller when unplug the battery connector; do not unplug the wire directly.

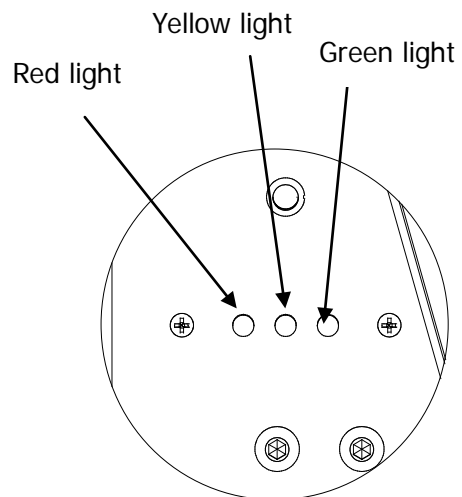

#### 6.5 Power Lamp Indicator

- Green light always on: 70%-100% power
- Yellow light always on: 40%-70% power
- Red light always on: 10%-40% power
- Red lamp flashes: the battery is empty
- When the red light is on, indicating low battery, needs to recharge.
- Red light flashes as a warning, indicating the truck is about to stop, charging is in need. If continue to use, the power disconnect protection will automatically carry out.

#### 7. Maintenance

Whether a vehicle can be used satisfactorily depends on careful maintenance. Neglect of maintenance, which may endanger personal safety and damage property. Therefore, checks

should be made regularly, abnormal phenomena should be eliminated in time, and faulty cars should not be used to ensure safety and prolong the service life of cars.

Maintenance of this pallet truck is generally divided into three levels: daily maintenance, weekly maintenance and Periodic Maintenance .

**Daily maintenance:** To keep the surface clean and examine if the power supply cable is damaged.

**Weekly Maintenance:** To check the condition of the operational components, all fastening items, if oil leakage, if abnormal wearing in mechanical components exists, if abnormal temperature rises or sparks in electric equipment, etc.

#### **Periodic Maintenance**

- a. Mechanical maintenance: do it every 3 months. Main content is to check whether the fasteners are loose, whether the wheels works flexibly and whether the fork lifts normally. The running noise of the vehicle after maintenance is not more than 75 dB.
- b. Hydraulic maintenance: do it yearly to check whether the cylinder is in normal condition, whether there are internal and external leakage. Whether the hydraulic oil is clean or not, which is usually replaced once in 12 months. Hydraulic oil adopts ISO standard. L-HV32 and L-HV15 cryogenic hydraulic oils are used when the ambient temperature is -5-40 and -10-5 respectively. The waste oil replaced shall be treated in accordance with the relevant local laws and regulations. Check whether the limit valve is working properly
- c. Electrical Maintenance: do it every 3 month to check whether the electrical connectors are reliable, whether the switches are normal, and check whether the electrical insulation is normal (the insulation resistance between the electrical part and the car body should be greater than  $0.5M \Omega$  ).

### **7.1 Adding hydraulic oil**

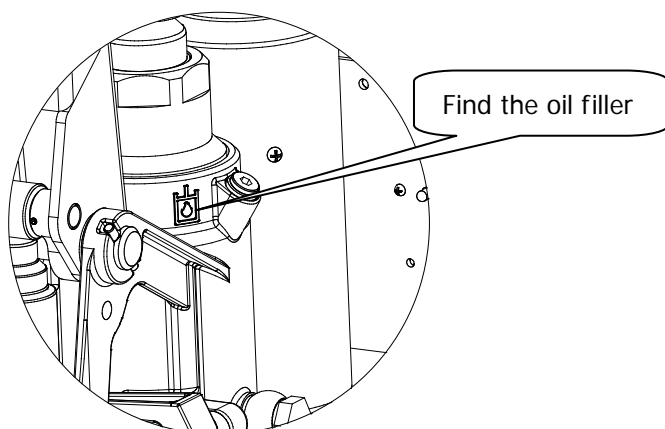

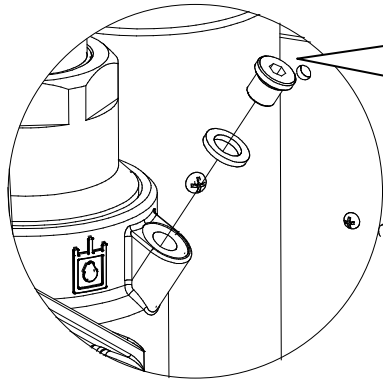

Remove the screw at the oil filler with No.5 hexagon wrench, the oil volume is 250ml.

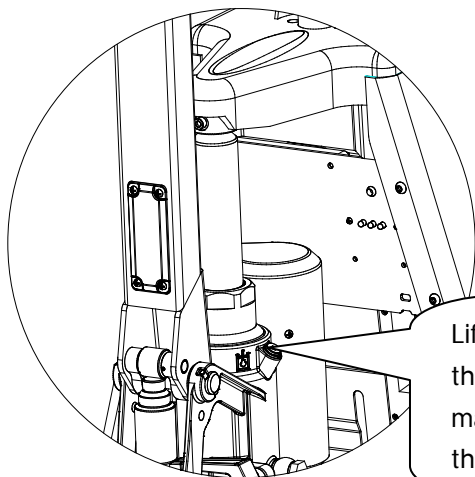

Lifting and lowering the handle for two to three times after oil filling, then lift the fork to max. height and tighten the screw. Replace the washer if its damaged.

## 8. Truck hoisting

Fasten the truck as shown in the drawing to hoist

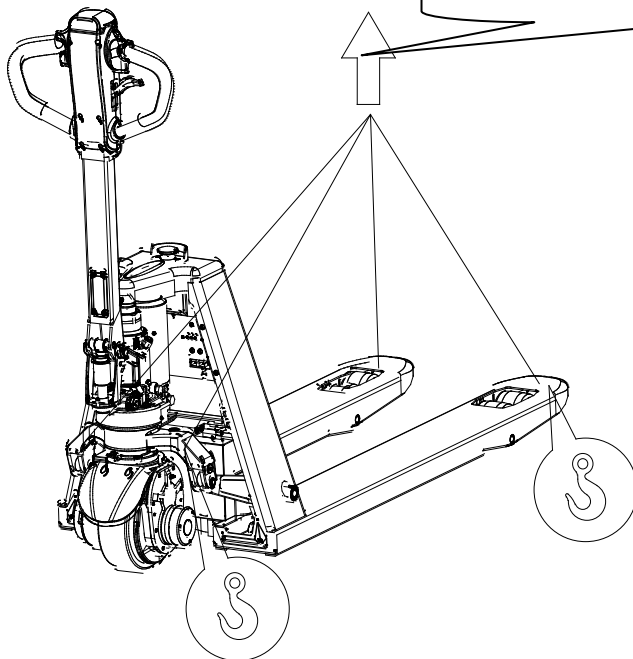

## 9. Trouble shooting

The table below provides some common failures of the truck in operation and the trouble shooting

No.	Faults	Analysis of cause	Trouble shooting
1	Hydraulic oil leakage	<ol style="list-style-type: none"> <li>1. Failed oil seal</li> <li>2. Slight damage or wear on the surface of one or two components</li> <li>3. Loose connection</li> </ol>	<ol style="list-style-type: none"> <li>1. Replace the oil seal</li> <li>2. Replace the damaged components</li> <li>3. Re-tighten the connection</li> </ol>
2	Lifting failure	<ol style="list-style-type: none"> <li>1. Too great viscosity of hydraulic oil or hydraulic oil has not been injected</li> <li>2. Foreign matters in the oil</li> <li>3. The hydraulic power unit is damaged</li> </ol>	<ol style="list-style-type: none"> <li>1. Replace hydraulic oil</li> <li>2. Remove the foreign matter in oil or replace hydraulic oil</li> <li>3. Replace the hydraulic power unit</li> </ol>
3	Lower failure	Manual lowering valve is not adjusted well	Adjust the position of lowering valve screw
4	Motor failure	<ol style="list-style-type: none"> <li>1. Power supply switch has not been turned on</li> <li>2. Battery has completely discharged</li> <li>3. Brake has not been released</li> <li>4. Burnt fuse</li> </ol>	<ol style="list-style-type: none"> <li>1. Insert key and turn on power</li> <li>2. Charge</li> <li>3. Examine the stroke switch on the lever if it is pressed because of collision and if the braking switch has been reset.</li> <li>4. Replace the fuse</li> </ol>
5	Charge failure	Damaged charger	Replace the charger

## 10. Waste treatment

The abandoned batteries and hydraulic oil should not be placed carelessly and must be treated according to the relevant local regulations and laws. Attention must be paid to environmental protection.

## 11. Accessories and spare parts

No.	Name	Application site	Specification	Qty(pc)	Remarks
1	Charger	Lithium battery charging		1	
2	Fuse 10A	Electrical part		1	
3	Fuse 60A	Electrical part		1	
4	Cable tie	Bundle handle harness	3X150	1	
5	Fixed button	Fix the wiring harness	ACC-2-B	1	
6	Screw	Fix the airing harness	M4X6	1	

## 12. Electrical schematic diagram

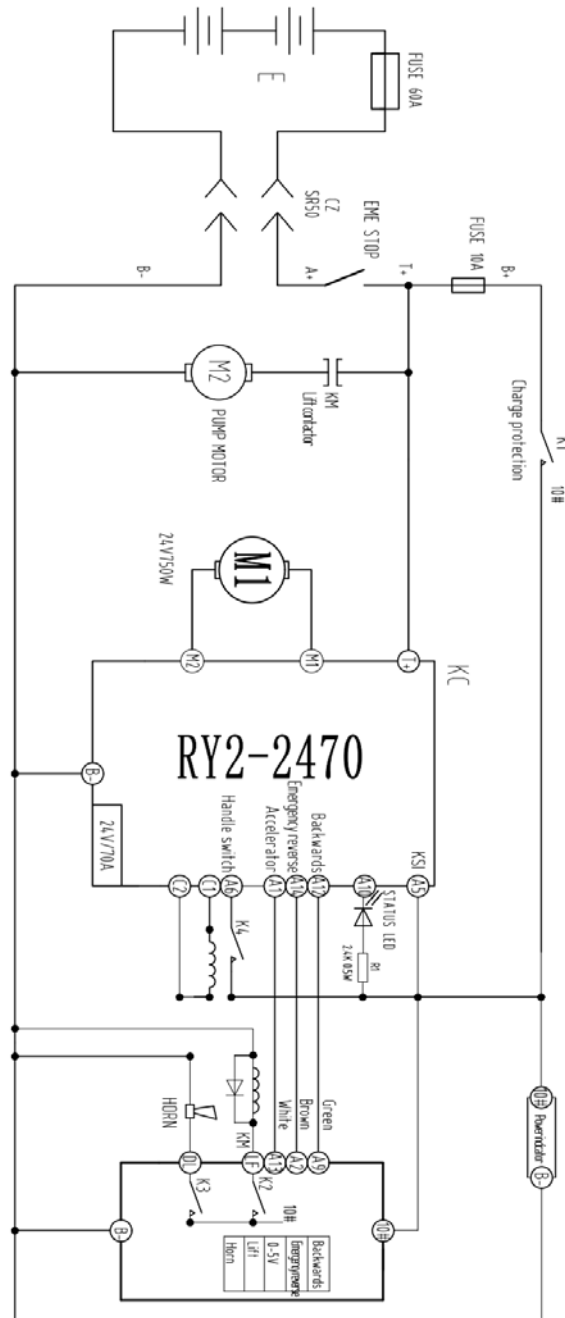

## 13. Packing list

### Packing list of CBD15 pallet truck with Lithium battery

Consignee: :

Ex-work No:

Contract No.:

Ex-work Date:

No.	Product Name	QT Y	Net. Weight (kg)	Dimension (L×W×H)	Remarks
1	CBD15 pallet truck	1			A complete set



2	Accessory box	1			Technical documents, accessories and spare parts.

Note: 1. The following documents are in the file bag:

- |    |                           |          |
|----|---------------------------|----------|
| 1. | CBD15 operation manual    | 1 volume |
| 2. | CBD15 parts catalogue     | 1 volume |
| 3. | Qualification certificate | 1 copy   |
| 4. | Packing list              | 1 copy   |

2. Accessories and spare parts

No.	Name	Application	Specification	Qty(pc)	Remarks
1	Charger	Lithium battery charging		1	
2	Fuse 10A	Electrical part		1	
3	Fuse 60A	Electrical part		1	
4	Cable tie	Bundle handle harness	3X150	1	
5	Fixed button	Fix the wiring harness	ACC-2-B	1	
6	Screw	Fix the airing harness	M4X6	1	

Consignor: Ningbo Ruyi Joint stock Co,ltd