

(NOTE: DESIGNER LOCKER SHOWN WITHOUT SIDE PANEL OR SLOPING HOOD. PLEASE ORDER SEPARATELY.)

**MODEL #27361  
15" WIDE DOUBLE TIER 'S' STYLE  
DESIGNER WOOD LOCKER – 3 WIDE**

(6) LOCKER COMPARTMENTS  
EACH COMPARTMENT:  
13-3/4" W x 40-3/4" H x 19-3/4" D

(THE DOUBLE TIER 'S' STYLE DESIGNER LOCKER INCREASES EACH COMPARTMENT ON ONE SIDE TO ACCOMMODATE GARMENTS.)

(BASES ARE MADE OF INDUSTRIAL GRADE PARTICLEBOARD AND ARE COVERED IN A DURABLE BLACK LAMINATE. PLEASE SET BASE TO ALLOW 5/8" BETWEEN THE BACK OF THE LOCKER AND THE WALL FOR AIR VENTILATION.)

**SIDE VIEW**

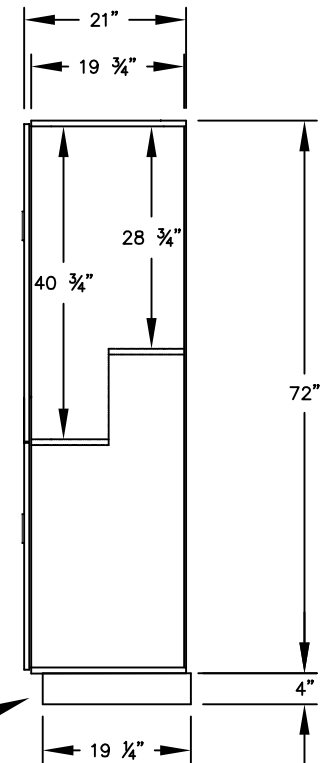

**MODEL #27361**

15" WIDE DOUBLE TIER 'S' STYLE  
DESIGNER WOOD LOCKER  
SIX FEET HIGH (ADD 4" FOR BASE)

AVAILABLE FINISHES: GRAY, BLUE, BLACK,  
MAPLE, CHERRY OR MAHOGANY

DRAWN: 3/2020

***Established in 1936, Salsbury Industries is the industry leader in manufacturing and distributing quality lockers.***

18300 CENTRAL AVENUE  
CARSON, CA 90746-4008  
PHONE: (800) 562-5377  
FAX: (800) 562-5399