

Planter Box 6' Bench

For Fastener Pack

FS-PB6F-CAP-01

Planter Box's are sold separately

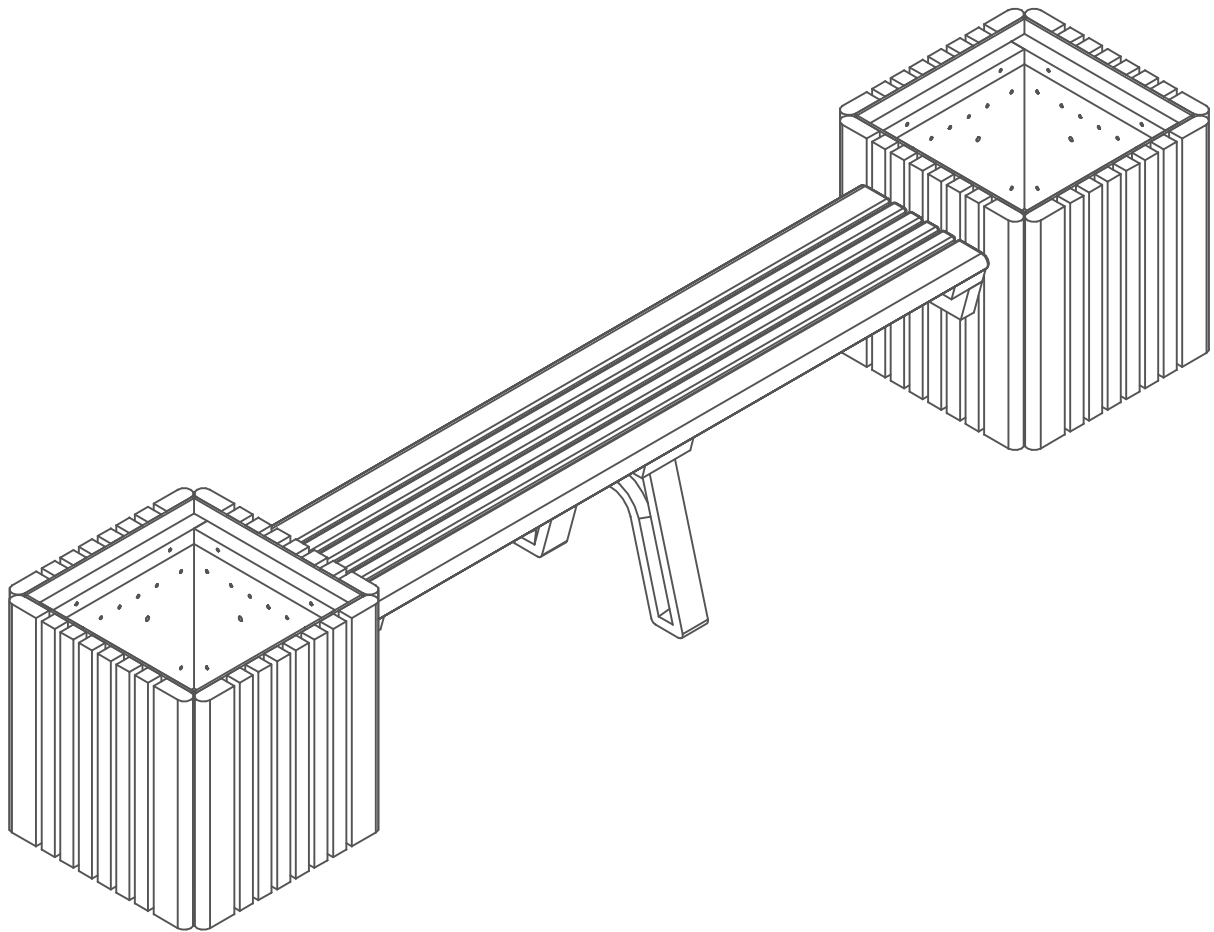

Congratulations ! !

You have just purchased the finest recycled plastic planters box 6' bench available. Enjoy ! ! !

Before assembly, please make sure all components are included.



(1) - One Fastener Pack
FP-PB6F-CAP-01

FP - Fastener Pack

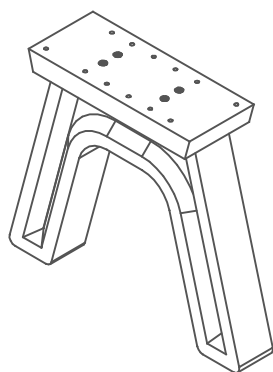

(1) - Center Bench End
BSA-FME-C-01

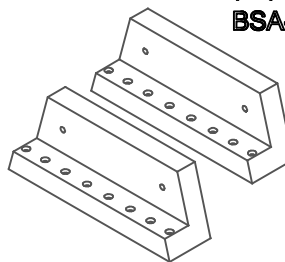

(2) - Support Assembly
BSA-PB6F-A-01

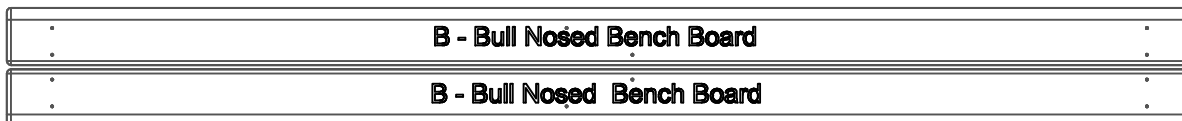

(2) - Two Bull Nosed Bench Boards
BP-PB6F-A-01

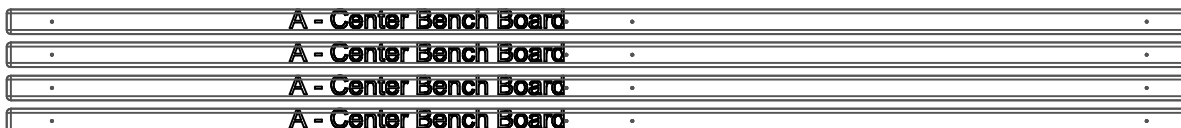

(4) - Four Center Bench Boards
BP-PB6F-B-01

Before assembly, please make sure all fasteners are included.

28 - #12 x 2 1/2" Flat Head Phillips Screw



4 - 3/8" x 4" Hex Head Tap Bolt

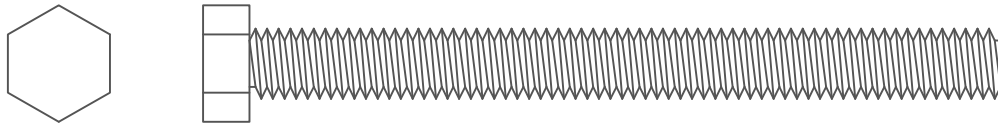

8 - 3/8" Flat Washer

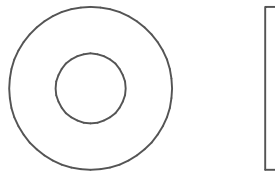

4 - 3/8" Nylon Lock Nut

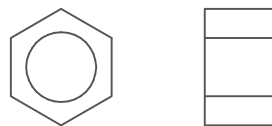

Also needed for this assembly will be the following materials:

1 - #3 Phillips Drive Bit

2 - 9/16" Socket Wrench

Step #6:

Place the Center Bench Boards on a level surface with the pilot holes facing up. On each side of the Center Bench Boards place (1) One Side Bench Board with the pilot holes closest to the Center Bench Boards and facing up.

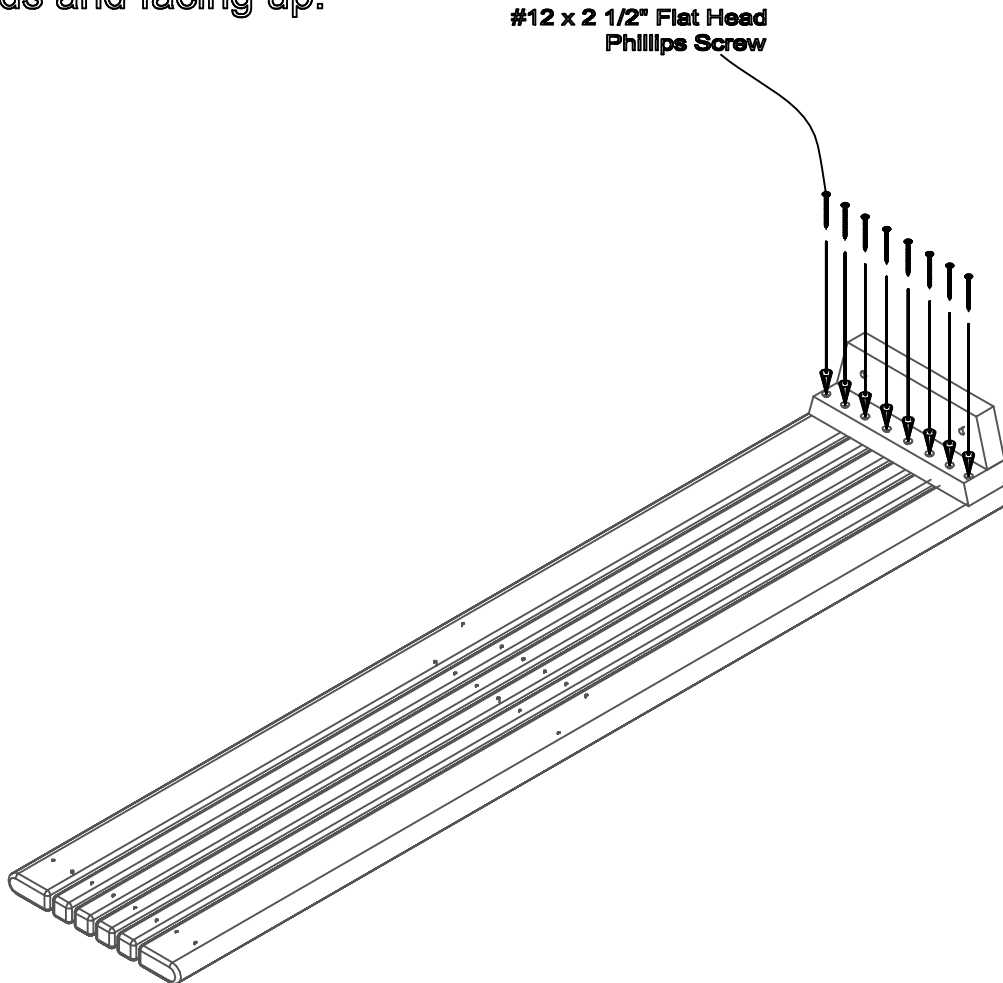

Step #7:

Place (1) One Bench End in position as shown above being sure to align the pre-drilled holes to the pilot holes in the bench boards. After the holes are properly aligned, fasten with (1) One #12 x 2 1/2" Flat Head Phillips Screw per hole to secure.

Note: Do not tighten screw completely. This will be done in a later step.

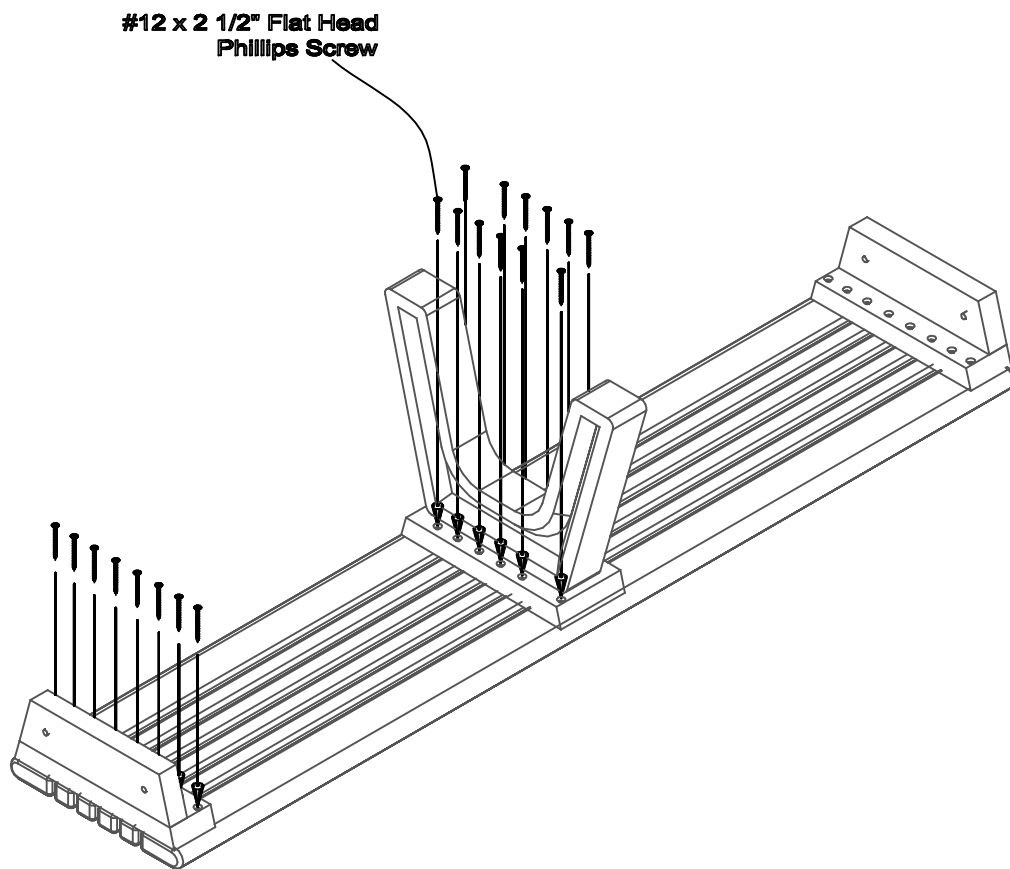

Step #8:

Place the remaining Bench End and Center Bench End in position as shown above being sure to align the pre-drilled holes to the pilot holes in the bench boards. After the holes are properly aligned, fasten with (1) One #12 x 2 1/2" Flat Head Phillips Screw per hole to secure.

Note: Be sure to tighten all screws completely after this step.

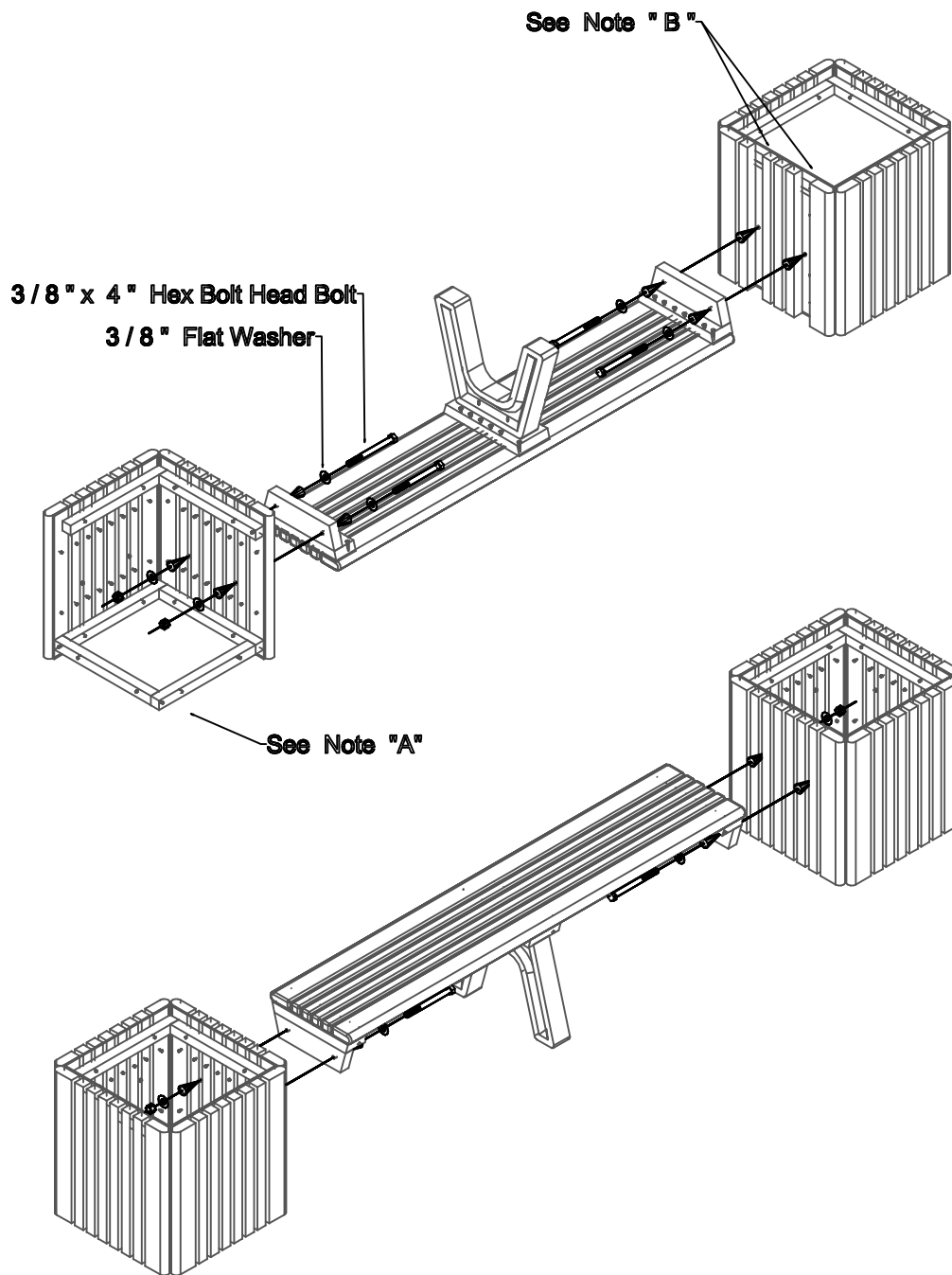

Step #9:

With both Planter Boxes Upright, Align the Pre-drilled holes in " Bench End " with Predrilled holes in side panels of " Planter Box " (See Diagram above). Use (1) one 3/8" x 4" hex bolt head bolt, (2) 3/8" Flat Washer, and (1) one Nylon Lock Nut per hole to secure.

** Note A - Bench is upside down and Side Panels have Been removed for clarity (Do Not Remove)

** Note B - Boards have Been removed for clarity (Do Not Remove)

DEAR VALUED CUSTOMER,

THANK YOU FOR PURCHASING THIS PRODUCT. THIS PRODUCT IS MANUFACTURED USING RECYCLED MATERIALS AND MAY HAVE SLIGHT COLOR VARIATIONS, OCCASIONAL SPECKS OF COLOR OR IRREGULAR SURFACE PATTERNS. THESE ARE NORMAL CONDITIONS OF RECYCLED PLASTICS AND MAKE EACH PIECE OF FURNITURE UNIQUE. THESE CHARACTERISTICS DO NOT AFFECT THE STRENGTH, QUALITY OR PERFORMANCE OF THE PRODUCT.

THANK YOU AGAIN FOR PURCHASING THIS PRODUCT AND HELPING OUR ENVIRONMENT.