



ELECTRIC CHAIN HOIST H3 DUTY CLASS Overload Protected 115V/1P/60HZ

MODELS:

OZ500EC

OZ1000EC

OZ2000EC

OZ4000EC



CAUTION

READ AND UNDERSTAND THIS MANUAL
BEFORE INSTALLATION AND OPERATION
OF YOUR ELECTRIC HOIST



P.O. Box 845, Winona, MN 55987

Phone (800) 749-1064

(507) 474-6250

Tech Support (507) 457-3346

Fax (507) 452-5217

sales@ozliftingproducts.com

TABLE OF CONTENTS:

Pg.2	Warranty
Pg.3-5	Dimensions and Specifications / Safety Precautions / Product Warnings
Pg.5	ASME Duty Classifications
Pg.6	Terms and Summary / Operation Personnel
Pg.7	Run Time Limits
Pg.8-10	Installation
Pg.11-13	Maintenance
Pg.13-18	Inspection
Pg.19	Troubleshooting
Pg.20	Repair Parts Ordering Instructions
Pg.21	Wiring Diagram
Pg.22-25	Parts Breakdown / Parts List

WARRANTY:

OZ Lifting Products, LLC® guarantees this product to be free of defects in materials and workmanship for one year from the date of shipment.

This warranty does not apply to products that show signs of misuse, overloading, alteration, improper maintenance or negligence. The normal wear and tear of moving parts is excluded from the warranty. Moving parts are defined as brake discs, wire rope and other wear components that are subject to use conditions. This warranty does not cover any costs related to removal of this product, lost time, or any other incidental or consequential damages/costs resulting from the claimed defects.

If this product fails during the first year of operating due to defective materials or workmanship, it will be repaired or replaced at the discretion of OZ Lifting Products, LLC®. Any product subject to a warranty claim must be returned, prepaid, to an authorized OZ Lifting Products, LLC® warranty depot along with proof of purchase. Upon repair, the product will be returned to the customer free of charge. If no defect is found, the customer will be responsible for return shipping costs. The product's warranty will be effective for the remainder of the original warranty period (one year from shipment date).

OZ Lifting Products, LLC® will not be held liable for the following arising from the use of this product: injuries to persons or property, death, incidental, consequential, or contingent damages, whether negligent or deliberate. It is the sole responsibility of the owner to install and operate the product properly and safely.

This is OZ Lifting Products, LLC®'s only written warranty. This warranty is in lieu of all other warranties implied by law such as merchantability and fitness. The sale of products from OZ Lifting Products, LLC® under any other warranty or guarantee, expressed or implied, is not authorized.

NOTE: OZ Lifting Products, LLC® has the right to alter the design of or discontinue the production of any product without prior notice.



P.O. Box 845, Winona, MN 55987
Phone (800) 749-1064
(507) 474-6250
Tech Support (507) 457-3346
Fax (507) 452-5217
sales@ozliftingproducts.com
www.ozliftingproducts.com

DIMENSIONS AND SPECIFICATIONS:

MODEL SPECIFICATION AND DIMENSIONS						
Model	OZ500EC	OZ1000EC	OZ2000EC	OZ2000EC	OZ4000EC	OZ4000EC
Serial Number Series	Any	Any	Start with "OZK"	Start with "V"	Start with "OZ4"	Start with "V"
Capacity	500 lbs.	1,000 lbs.	2,000 lbs.	2,000 lbs.	4,000 lbs.	4,000 lbs.
Load Chain Falls	1	1	1	1	2	2
Chain Size	4.0 mm.	6.3 mm.	7.1 mm.	7.1 mm.	7.1 mm.	7.1 mm.
Lifting Speed	12.5 FPM	20 FPM	13 FPM	17 FPM	6.5 FPM	8.5 FPM
Motor - Electrical 115V-60Hz	180W/4A	1400W/10A	1800W/13A	2500W/13A	1800W/13A	2500W/13A
Duty Cycle	15 min.	18 min.	18 min.	18 min.	18 min.	18 min.
Pendant Length	15'	19'	19'	19'	19'	19'
Power Cord Length	15'	15'	15'	5'	15'	5'
Net Weight	18 lbs.	53 lbs.	59 lbs.	60 lbs.	84 lbs.	80 lbs.
A	5.00"	8.27"	8.27"	8.50"	10.63"	8.50"
B	15.00"	27.00"	28.00"	26.00"	30.00"	26.00"
C	9.50"	17.72"	20.08"	22.08"	20.08"	22.08"
D - Headroom	11.00"	16.93"	18.90"	19.00"	24.40"	30.00"
E	0.60"	1.02"	1.14"	1.15"	1.61"	1.65"
F	2.50"	3.35"	3.90"	4.27"	5.00"	5.17"
G	0.75"	1.06"	1.22"	1.19"	1.50"	1.35"

*Dimensions are for reference only and subject to change without notice.

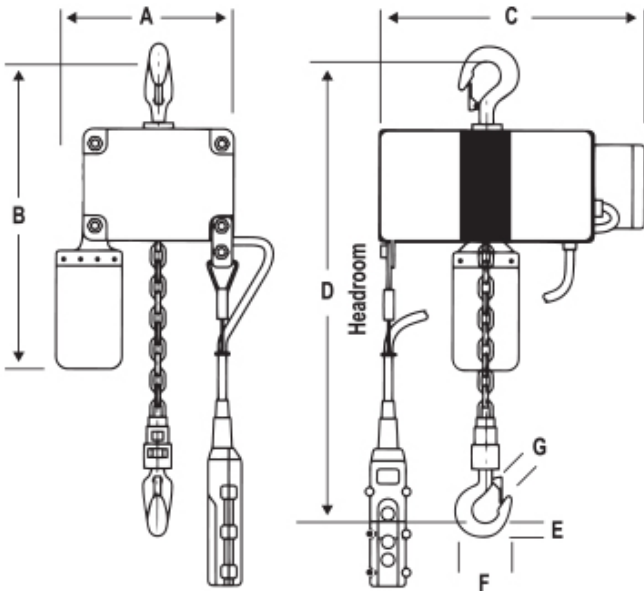

SAFETY PRECAUTIONS:

Throughout the manual are safety precautions and instructions for awareness, along with information on potential hazards. Due to the complexities of this hoist and the environment in which it operates, situations may arise which are not directly discussed in detail in this manual.

This manual is provided as a guide to personnel involved with the operation and maintenance of the hoist equipment. Only trained and qualified personnel can operate and maintain this equipment. We recommend that all personnel who operate and maintain the hoist review and become familiar with this manual. In addition, we recommend that this manual be kept readily available for reference before beginning operation, maintenance and testing of this equipment.

Most accidents involving hoist are the result of violating safety rules during operation and/or lack of inspection and maintenance procedures.

PRODUCT WARNINGS:



Warning indicates an imminently hazardous situation which, if not avoided, could result in death or serious injury, and property damage.

DON'Ts

- DON'T** operate the hoist until you have read the Operating, Maintenance and parts manual.
- DON'T** use the hoist to lift, support or transport people.
- DON'T** lift loads over personnel.
- DON'T** operate the hoist until all personnel are clear of the supported load.
- DON'T** operate a hoist which has been modified without the manufacturer's approval or without certification.
- DON'T** operate a hoist unless the load slings or other approved single attachments are properly sized and seated in the hook saddle.
- DON'T** use load chain as a sling or wrap the chain around the load.
- DON'T** use hoist with twisted, kinked, damaged or worn load chain.
- DON'T** operate a hoist on which the safety place cards or decals are missing or illegible.
- DON'T** operate a damaged or malfunctioning hoist.
- DON'T** remove or obscure the warning labels on the hoist.
- DON'T** lift more than the rated load for the hoist.
- DON'T** apply the load unless load chain is properly seated in the chain sprocket(s).
- DON'T** operate hoist when it is restricted from forming a straight line from hook to hook in the direction of loading.
- DON'T** operate beyond the limits of the load chain travel.
- DON'T** leave the load unattended unless specific precautions have been taken.
- DON'T** apply the load to the tip of the hook or to the hook latch.
- DON'T** attempt to lengthen the load chain or repair the damaged load chain.
- DON'T** apply load if bearing prevents equal loading on all load supporting chains.
- DON'T** operate unless load is centered under the hoist properly.
- DON'T** operate a hoist until it has been securely attached to a suitable support.
- DON'T** allow the load chain or hook to be used as an electrical or welding ground.
- DON'T** allow the load chain or hook to be touched by a live welding electrode.

DO's

- DO** shut down a hoist immediately if it malfunctions or performs unusually and report such malfunction.
- DO** warn personnel of an approaching load.
- DO** make sure that the hoists limit switches function properly.
- DO** take up slack carefully - make sure the load is balanced and the load holding action is secure before continuing.
- DO** protect the hoist's load chain from weld splatter or other damaging contaminants.

PRODUCT CAUTIONS:



Caution indicates a potentially hazardous situation which, if not avoided, may result in minor or moderate injury, or property damage.

DON'Ts

- DON'T** adjust or repair the hoist unless qualified to perform such adjustments or repairs.
- DON'T** allow the hoist to be subjected to sharp contact with other hoist, structures or objects through misuse.
- DON'T** allow your attention to be diverted from operating the hoist.
- DON'T** use the hoist overload limiting clutch to measure the load.

DO's

- DO** inspect the hoist regularly, replace damaged or worn parts and keep appropriate records of maintenance.
- DO** lubricate load chain per hoist manufacturer's recommendations.
- DO** use OZ Lifting Products recommended parts when repairing the hoist unit.
- DO** check brake function by tensioning the hoist prior to each lift operation.
- DO** maintain firm footing or be otherwise secured when operating the hoist.
- DO** make sure the hook latches are closed and not supporting any parts of the load.
- DO** use hook latches. Latches are to retain slings, chains, etc. under slack conditions only.
- DO** avoid swinging the load or hook.
- DO** make sure the load is free to move and will clear all obstructions.
- DO** make sure the hook travel is in the same direction as shown on the controls.

ASME DUTY CLASSIFICATION:

ASME Duty Classes	Service Classification	Description
H1	Infrequent or Standby	Idle 1-6 months, use for installations and/or maintenance
H2	Light	Light maintenance, fabrication, capacity loads infrequently handled, randomly distributed loads, low running time
H3	Standard	General machining, randomly distributed loads, total running time $\leq 25\%$ of working period
H4	Heavy	High volume handling of heavy loads near rated capacity, steel warehousing, machining, foundries, total running time $\leq 50\%$ of working period
H5	Severe	Bulk material handling with attachments, approach continuous operation

TERMS AND SUMMARY:

NOTICE, CAUTION, WARNING AND DANGER:

This manual contains important information to help you properly install, operate and maintain the **OZ500EC**, **OZ1000EC**, **OZ2000EC** and **OZ4000EC** for maximum performance and safety purpose. Although you may be familiar with this equipment or similar equipment, it is very strongly recommended that you read this manual before attempting to operate, install or maintain the product. Please study the contents thoroughly before putting the HOIST in operation. The following signal words are used to identify the degree or level of hazard seriousness. Follow all instructions and warnings, failure to operate equipment as directed in manual may cause injury or property damage.



NOTICE

Notice is used to notify people of installation, operation or maintenance information which is important but not directly hazard related.



WARNING

Warning indicates an imminently hazardous situation which, if not avoided, could result in death or serious injury and property damage.



CAUTION

Caution indicates a potentially hazardous situation which, if not avoided, may result in minor or moderate injury or property damage.



DANGER

Caution indicates a potentially hazardous situation which, if not avoided, may result in minor or moderate injury, or property damage.

OPERATION PERSONNEL:

For independent operation or maintenance of chain hoist, the owner may only employ persons as following:

This manual contains important information to help you properly install, operate and maintain the **OZ500EC**, **OZ1000EC**, **OZ2000EC** and **OZ4000EC** for maximum performance and safety purpose. Although you may be familiar with this equipment or similar equipment, it is very strongly recommended that you read this manual before attempting to operate, install or maintain the product. Please study the contents thoroughly before putting the HOIST in operation. The following signal words are used to identify the degree or level of hazard seriousness. Follow all instructions and warnings, failure to operate equipment as directed in manual may cause injury or property damage.



WARNING

OZ500EC, **OZ1000EC**, **OZ2000EC** and **OZ4000EC** operators should read and fully comprehend this entire manual and all warnings on the hoist before use. If this manual is not read and followed completely, injuries may occur.

All Persons MUST: Be trained in proper operation and in dealing with potential malfunctions of lifting equipment. Abstain from use of alcohol, medications, or drugs while operating. Avoid operation while tired or distracted. Avoid operation if they have a history of seizures or other medical issues that may interfere with operation.

NOTE: Prior to operation, ensure that the hoist is in proper working condition and maintenance records are up to date.

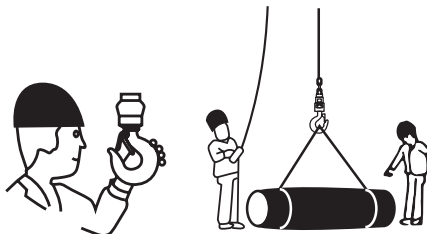

RUN TIME LIMITS:

Rated Percentage Duty Cycle (%ED):



Do not exceed the rated duty cycle

The service life of the product is significantly dependent on the frequency at which it is operated. To ensure long service life, operate the winch within its rated percentage duty cycle (%ED). The rated percentage duty cycle (%ED) is expressed by the duty factor (%ED) obtained at the rated voltage and

$$\text{percentage duty cycle (\%ED)} = \frac{\text{lifting time} + \text{lowering time}}{\text{lifting time} + \text{idle time} + \text{lowering time} + \text{idle time}} \%$$

The maximum startup frequency represents the frequency of startup operations per hours, including inching operations. The rated speed, which indicates the average speed of winding up or down at a rated load. A cycle is limited at 10 minutes at most.

Rated Percentage Duty Cycle (%ED):

Load Spectrum	State of Loading	Cubic Mean Value	Average Daily Operating Time in Hours	Calculated Total Operating Time in Hours
Light	Occasional full load; Usually light load; Small fixed load	$k \leq 0.5$	$2 \leq$	3,200
Medium	Occasional full load; Usually light load; Average fixed load	$0.5 < k \leq 0.63$	$1 \leq$	1,600
Heavy	Repetitive full load; Usually average load; Heavy fixed load	$0.63 < k \leq 0.8$	$0.5 \leq$	800
Very Heavy	Usually almost full load; Very heavy fixed load	$0.8 < k \leq 1$	$0.25 \leq$	400

Load %

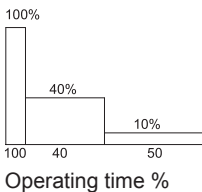

Load %

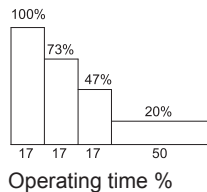

Load %

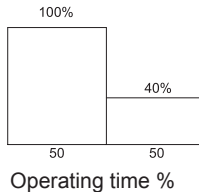

Load %

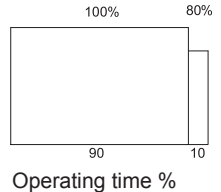

INSTALLATION:

A. PRE-INSTALLATION CHECKS:

1. Check for transit damage.
2. Check that all external wiring is in good order.
3. Check that the load chain is in good order.
4. Check that all fasteners and joints are tight and secure.
5. Check the capacity of the lifting unit and bottom block.

B. POWER SUPPLY SYSTEM:

To insure proper operation, to avoid damage to the hoist and electrical system, and to reduce the risk of electrical shock or fire, the branch circuit supplying power to the hoist must:

1. Effectively ground the hoist in accordance with the National Electrical Code and other applicable codes. Proper grounding provides a path with the least resistance for the electrical current to travel reducing the risk of electrical shock. The standard power cord is equipped with a three prong plug, used with our 115V unit. Make sure that the receptacle opening that receives the longest prong is properly grounded.
2. Be in accordance with the National Electrical Code (ANST/NFPA-70) and applicable National, State and Local codes.
3. Include a disconnecting means capable of being locked in the 'open' position.
4. Have ample capacity to prevent excessive voltage drop during starting and operation. When determining the size of branch circuit components and conductors, special consideration should be given to the starting current amps (approximately three times that shown on the hoist identification plate) and the length of the conductors. As a minimum, the system should be rated for 20 amps and the system should have #14 AWG or larger, wiring.
5. Include slow blow type fuses or inverse trip time circuit breakers to permit the hoist to start and accelerate the load.



Failure to properly ground the hoist presents the danger of electric shock.
To avoid injury: Permanently ground the hoist as instructed in this manual.



Failure to provide a proper power supply system for the hoist may cause hoist damage and offers the potential for a fire.
To avoid injury: Provide the hoist with a 20 amp, minimum, over current protected power supply per the National Electrical Code (ANSI/NFPA 70) and applicable local codes as instructed in this manual.

C. CONNECTION TO THE ELECTRICAL SUPPLY:

An adequate supply system is required along the total length of travel (where appropriate). The supply voltage and frequency at which the hoist operates, is marked on the motor rating plate. It is imperative to check before connecting the unit that these figures correspond with those of the supply voltage.

D. MOUNTING THE HOIST:

Hang the hoist from its intended support. The structure used to support the hoist must have sufficient strength to withstand several times the load amount. If you are not sure of the weight the structure can hold, consult a registered engineer and the local building codes.



Suspending the hoist from an inadequate support could allow the hoist and load to fall and cause personal injury and/or property damage.

To avoid injury: Make sure that the structure has sufficient strength to withstand several times the hoist and its rated load amount. Using the upper hook, hang the hoist from the support. Make sure the hoist is solidly held in the uppermost part of the hook arc and the latch is tightly against the hook tip.

E. LOAD CHAIN:

The chain should feed smoothly into and away from the hoist and hook block (1/2 ton and 1 ton). If the chain binds, jumps or is noisy, First clean and lubricate the chain, if trouble persists inspect chain and mating parts for wear, distortion and other damages.

F. HOOK AND EYE SUSPENSION HOISTS:

The suspension point should be of a correct size to admit the top hook or eye of the hoist and allow it to rest properly on the saddle. It must be adequate to support the hoist while it is being operated at its maximum capacity (safe working load).

G. CHAIN CONTAINER:

For installations where the slack chain hanging from the hoist may be objectionable or hazardous, the use of a chain container is recommended.



Do not attempt to store more chain in the chain container than what is specified for the hoist or serious damage to hoist may result and hazardous conditions may be created.

INSTALLATION OF STANDARD CHAIN CONTAINER:

1. Remove both bolts from the chain container mounting bracket.
2. Attach the chain container to the bracket.
3. Reinsert the bolts.

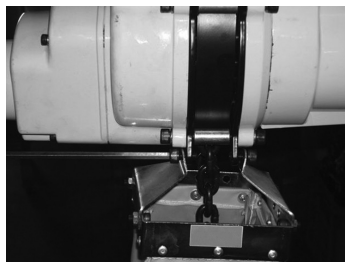

H. TEST AND OPERATIONAL CHECKS:

On completion of installation, but before the hoist is put into regular service, the following procedure should be carried out:

1. Record the hoist's Code, Lot and Serial Number from the name plate on the hoist.
2. Check that the hoist is properly installed to either a fixed point or trolley, whichever applies.
3. If hoist is installed on a trolley, ensure that:
 - The trolley is properly installed on the beam.
 - The stops for the trolley are correctly positioned and securely installed on the beam.
4. Isolate the power supply.
5. Check that all mechanical and electrical joints and connections are tight and secure.
6. Check that all nuts, bolts and split pins (cotter pins) are securely fastened.
7. Confirm proper operation:
 - Before operating read and become familiar with this manual.
 - Before operating check to ensure that the hoist (and trolley) meet the Inspection, Testing and Maintenance requirements of ANSI/ASME B30.16.
 - Before operating check that nothing will interfere with the full range of the hoist's (and trolley's) operation.
8. Switch on the power supply.
9. Run lightly with no load, throughout the full extent of the hoist and check that the operation is smooth at all times.
10. Check the operation of the hoist brake, run under light load and full load conditions.



Check supply voltage before everyday use. If the voltage varies more than 10% of the rated value, electrical devices may not function normally.



Confirm the adequacy of the rated capacity for all slings, chains, wire ropes and all other lifting attachments before use. Inspect all load suspension members for damage prior to use and replace or repair all damaged parts.



Verify and correct all chain irregularities prior to operating the hoist.

I. UNPACKING:

Once package has been opened, carefully inspect the hoist frame, hooks, chain and control station for damage that may have occurred during shipment.



Operating a unit with obvious external damage may cause load to drop and could result in personal injury and/or property damage.

To avoid injury: Carefully check unit for external damage prior to installation.

Make sure to check that the power supply to which the hoist is to be connected matches the information shown on the identification plate located on the bottom of the hoist.

BEFORE USING THE HOIST, FILL IN THE INFORMATION BELOW:

Model No.: _____

Serial No.: _____

Purchase Date: _____

MAINTENANCE:

A. CHAIN INSPECTION:

1. First clean chain with a non-caustic/non-acid type solvent and make a link by link inspection for nicks, gouges, twisted links, weld splatter, corrosion pits, striations (minute parallel lines), cracks in weld areas, wear and stretching. A chain with any of these defects must be replaced before use.
2. When checking the chain for wear, check the part of the chain that goes through the lift wheel of the hoist most often. Check the interlink area of the chain links for the point of maximum wear. Measure and record the stock diameter at this point of the link. Then measure stock diameter in the same area on a link that does not pass through the lift wheel. Compare these two measurements. If the stock diameter of the worn link is 0.010 inches or more, than the stock diameter of the unworn link, the chain must be replaced.
3. Check the chain for stretch with a vernier caliper. Select an unused, unstretched section of chain then measure and record the length. Measure and record the same length on a worn section of chain. Obtain the amount of stretch and wear by subtracting the measurement of the unworn section from the worn section. If the result is greater than 0.145 inch, the chain must be replaced.
4. Use only a 'Knife-edge' caliper to eliminate the possibility of false reading by not measuring full pitch length.
5. These chains are specially heat treated and hardened, they should never be repaired.

IMPORTANT: Do not use replaced chain for other purposes such as lifting or pulling. Load chain may break suddenly without visual deformation. For this reason, cut replaced chain into short lengths to prevent use after disposal.

NOTE: A worn chain can be an indication of worn hoist components. For this reason, the hoist's chain guide, hook block and lift wheel should be examined for wear and replaced as necessary when replacing worn chain.



Use of commercial or other manufactures' chain and parts to repair OZ Electric Chain Hoists may cause load loss. To avoid injury: Use only factory supplied replacement load chain and parts. Chain and parts may look alike, but factory original chain and parts are made of specific materials or processed to achieve specific properties.

A. CUTTING THE CHAIN:

The load chain is hardened and is difficult to cut. The following methods are recommended when cutting a length of new chain from stock or cutting off worn chain. (Always wear eye protection when cutting the load chain.)

1. Use a 7" minimum diameter by 1/8" thick abrasive wheel (or type recommended by your wheel supplier) that will clear the adjacent links.
2. Use a grinder and nick the link on both sides, then secure the link with a vise and break off the chain link with a hammer.



Cutting chain can produce flying particles.

To avoid health problems:

- Wear eye protection.
- Place shield over chain to prevent flying objects.

C. LUBRICATION:

1. **Load Chain:** The full length of the chain must be lubricated, including where the chain passes over the chain wheel(s). Ensure that the contact points between the links (I.E. the chain saddles) are adequately lubricated. A small amount of lubrication will greatly increase the life of the load chain. DO NOT allow the chain to run dry. Keep the chain clean and lubricate the chain at regular intervals with lubricating oil. Normally, weekly lubrication and cleaning is satisfactory, but under hot and dirty conditions, it may be necessary to clean the chain at least once daily and lubricate the chain several times between cleanings. When lubricating the chain, apply sufficient lubricant to obtain natural run-off and full coverage, especially in the interlink area.



Used motor oils contain known carcinogenic materials.
To avoid health problems: Never use used motor oils as a chain lubricant.

2. **Gearbox:** For ambient temperature of approx., 50 F to 122 F, a gear oil of Mm /S at 104 F, with mild high-pressure additives should be used.

Using incorrect type/grade of gearbox oil or the wrong quantity of oil may prevent the hoist from working properly and may affect the ability of the hoist to hold the load.

Gear box should be cleaned and lubricated with ISO VG460 synthetic gear lube every 100 working hours for initial lubrication and at least once per months for normal usage. Clean and lubricate more frequently for heavy usage.

Oil change requires 250 CC of oil.

3. **Important:** The bottom block must not touch the floor; if necessary adjust the position of the chain stop on the slack end of the chain.



The lubricants used for the OZ Electric Chain Hoist may contain hazardous materials that mandate specific handling and disposal procedures.
To avoid contact and contamination: Handle and dispose of lubricants only as directed in applicable material safety data sheets and in accordance with applicable local, state and federal regulations.

D. TESTING:

Before using, all altered, repaired or used hoists that have not been operated for the previous 12 months must be tested by the user for proper operation.

1. Test the unit without a load and then test the unit with a light load of 50 pounds (23 kg) times the number of load chain supporting parts to be sure that the hoist operates properly and that the brake holds the load when control is released.

2. Next test with a load of 125% of the rated capacity. In addition, hoists in which load sustaining parts have been replaced, you should test the load with 125% of rated capacity by or under an appointed person and a written report prepared for record purposes.

3. In accordance with the CMAA 78, it is required to have a 100% load test performed every four years.



The hoist must only be inspected and maintained by qualified, competent and trained personnel.

Table 7-1 Lubrication Chart

PART	DESCRIPTION	FREQUENCY
Cables	Check control cables and strain relief elements	Before each shift
Clutch	Check operation of the slipping clutch (if fitted)	Before each shift
Pendant	Check control pendant housing for damage	Before each shift
Hook	Check suspension eye/suspension hook assembly	After 50-200 service hours
Electrical	Check electrical switch gear and wiring	Before each shift, Monthly
Hook	Check tight fit of securing bolts on load hook assembly	Before each shift, After 50-200 service hours
Chain	Check ends of chain/chain bag to ensure they are secure	Before each shift
Chain	Lubricate chain, under normal usage Lubricate chain, under heavy usage	After 50-200 service hours
Oil	Check oil level and change oil (if needed)	Before each shift
Hook	Check hooks for cracks, deformation, pitting and wear	After 50-200 service hours
Clips/Bolts/Nuts	Check securing elements for tight fit and corrosion	After 50-200 service hours
Bottom Block	Lubricate chain sprocket bearing and check for a tight fit of securing bolts.	After 50-200 service hours
Brakes	Check operation of brakes	After 50-200 service hours
Brake	Check brake stroke, brake disc and adjust brake as required	After 50-200 service hours

INSPECTION:

A. GENERAL:

The inspection procedure is based on ANSI/ASME B30.16. The following definitions are from ANSI/ASME B30.16 and pertain to the inspection procedure below.

1. Qualified Person: A person who, by possession of a recognized degree or certificate of professional standing, or who, by extensive knowledge, training and experience has successfully demonstrated the ability to solve or resolve problems relating to the subject matter at work.
2. Designated Person: A person assigned or selected as being competent to perform the specific duties to which he/she is assigned.
3. Normal Service: A distributed service which involves operation with randomly distributed loads within the rated load limit or uniform loads less than 65% of rated load for not more than 25% of the time.
4. Heavy Service: A service which involves operation within the rated load limit which exceeds normal service.
5. Severe Service: A service which involves normal or heavy service with abnormal operating conditions.

B. INSPECTION METHODS AND CRITERIA:

This section covers the inspection of specific items. The list of items in this section is based on those listed in ANSI/ASME B30.16 for the Frequent and Periodic Inspection. In accordance with ANSI/ASME B30 volumes listed under the General heading on the previous pages, these inspections are not intended to involve disassembly of the hoist. Rather, disassembly for further inspection would be required if frequent or periodic inspection results so indicate. Such disassembly and further inspection should only be performed by a certified or qualified person trained in the disassembly and re-assembly of the hoist.

Table 8-1 Hoist Inspection Methods and Criteria

Item	Method	Criteria	Action
Functional operating mechanisms	Visual, Auditory	Mechanisms should be properly adjusted and should not produce unusual sounds when operated.	Repair or replace as required
Braking System Operation	Function	Braking distance with rated capacity should not exceed approximately five chain links.	Repair or replace as required
Hooks (surface condition)	Visual	Should be free of significant rust, weld splatter, deep nicks or gouges.	Replace
Hooks (stretch)	Measure	The "G" dimension should not exceed the measured value from Table 8-3.	Replace
Hooks (yoke assembly)	Visual	Should be free of significant rust, weld splatter, nicks or gouges. Holes should not be elongated, fasteners should not be loose and there should be no gap between mating parts.	Tighten or replace as required
Hooks (bent shank or neck)	Visual	Shank and neck portions of hook should be free of deformations.	Replace
Hooks (hook latches)	Visual, Function	Latch should not be deformed. Attachment of latch to hook should not be loose. Latch spring should not be missing and should not be weak. Latch movement should not be stiff-when depressed and released latch should snap smartly to its closed position.	Replace
Hooks (swivel bearing)	Visual, Function	Bearing parts and surfaces should not show significant wear. They should be free of dirt, grime and deformations. Hook should rotate freely with no roughness.	Clean/Lubricate, or replace as required
Load Chain (surface condition)	Visual	Should be free of rust, nicks, gouges, dents and weld spatter. Links should not be deformed or show signs of abrasion. Surfaces where links bear on one another should be free of significant wear.	Replace
Load Chain (lubrication)	Visual, Auditory	Entire surface of each link should be coated with lubricant and free of dirt/grime. Chain should not emit cracking noise when hoisting a load.	Clean/ Lubricate
Load Chain (pitch and wire diameter)	Measure	The "P" dimension should not be greater than maximum value or less than minimum value listed in Table 8-4.	Replace. Inspect Load Sheave by qualified personnel
Load Chain (reeving)	Visual	Chain should be reeved properly through load sheave. Chain, cushion rubbers, washers and stoppers should be installed properly.	Reeve/ Install chain properly
Chain Container	Visual	Container should not be damaged. Brackets should not be deformed or missing.	Replace
Housing and Mechanical Components	Visual, Auditory, Vibration, Function	Hoist components including load blocks, suspension housing, chain attachments, clevises, yokes, suspension bolts, shafts, gears, bearings, pins and rollers should be free of cracks, distortion, significant wear and corrosion. Evidence of same can be detected visually or via detection of unusual sounds or vibration during operation.	Replace
Bolts, Nuts and Rivets	Visual, Check with proper tool	Bolts, nuts and rivets should not be loose.	Tighten or replace as required

Table 8-1 Hoist Inspection Methods and Criteria

Item	Method	Criteria	Action
Motor Brushes	Measure, Visual	The "B" dimension should not be less than minimum value listed in Table 8-2.	Replace
Cushion Rubber	Visual	Should be free of significant deformation.	Replace
Contactors Contacts	Visual	Contacts should be free of significant pitting or deterioration.	Replace
Pendant (switches)	Function	Depressing and releasing push buttons should make and break contacts in switch contact block and result in corresponding electrical continuity or open circuit. Push buttons should be interlocked either mechanically or electrically to prevent simultaneous energization of circuits for opposing motions. Example: Up and Down	Repair or replace as necessary
Pendant (wiring)	Visual	Wire connections to switches in pendant should not be loose or damaged.	Tighten or repair
Pendant (housing)	Visual	Labels denoting functions should be legible.	Replace
Pendant (labels)	Visual	Pendant housing should be free of cracks and mating surfaces of parts should seal without gaps.	Replace
Pendant (cord)	Visual, Electrical Continuity	Surface of cord should be free from nicks, gouges and abrasions. Each conductor in cord should have 100% electrical continuity even when cord is flexed back and forth. Pendant cord strain relief cable should absorb the entire load associated with forces applied to the pendant.	Replace
Warning Labels	Visual	Warning labels should be affixed to the hoist and they should be legible.	Replace
Hoist Capacity Label	Visual	The label that indicates the capacity of the hoist should be legible and securely attached to the hoist.	Replace

Table 8-2 Motor Brush Dimensions

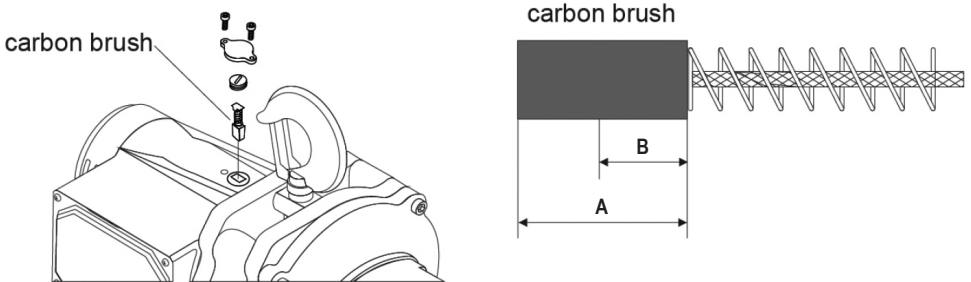

*Be sure to replace carbon brush on top of hoist (pictured above) as well on the bottom/opposite of above

Model	"A" Dimension (inches)	"B" Dimension (inches)
	Standard	Discard
OZ500EC	0.60	0.30
OZ1000EC, OZ2000EC, OZ4000EC	0.67	0.30

Table 8-3 Top Hook & Bottom Hook Dimensions (inches)

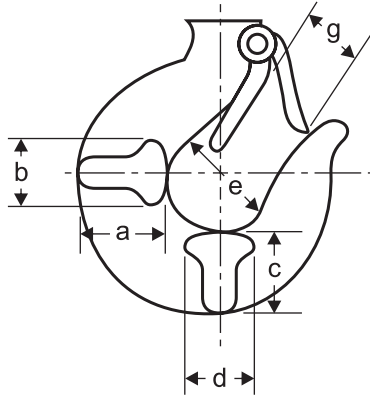

Model	T/B	a	b	c	d	e	g
OZ500EC	T/B	0.64	0.46	0.60	0.46	1.25	0.75
OZ100EC	T/B	1.14	0.76	1.02	0.76	1.09	0.87
OZ2000EC	T/B	1.30	0.91	1.14	0.91	1.56	1.22
OZ4000EC	T/B	1.77	1.22	1.61	1.22	1.81	1.50

These values are nominal since the dimension is not controlled to a tolerance. The “D” dimension should be measured when the hook is new, this becomes a reference measurement. Subsequent measurements are compared to this reference to make determinations about hook deformation/stretch.

Table 8-4 Chain Wear Dimensions

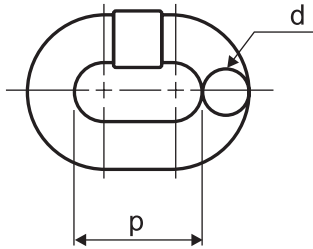

Model		OZ500EC	OZ1000EC	OZ2000EC/OZ4000EC
Standard Dimension	d	Ø 4.0	Ø 6.3	Ø 7.1
Limit Dimension	mm	Ø 3.6	Ø 5.7	Ø 6.4
Wear Standard Dimension	p	12.0	19.1	20.2
Wear Limit Dimension	mm	12.5	20.0	21.0

C. INSPECTION CLASSIFICATION:

The inspection procedure for hoist in regular service is divided into two general classifications based upon the intervals at which inspection should be performed. The intervals in turn are dependent upon the nature of the critical components of the hoist and the degree of their exposure to wear, deterioration or malfunction. The two general classifications are designated as Frequent and Periodic, with respective intervals between inspections as defined below.



Initial Inspection: Prior to initial use, all new, altered or modified hoist shall be inspected by a designated person to ensure compliance with the applicable provisions of this manual.

FREQUENT INSPECTIONS - Frequent inspections are visual examinations by the operator or other designated personnel with interval per the following criteria.

1. Normal Service- Monthly
2. Heavy Service - Weekly to Monthly
3. Severe Service- Daily to Weekly
4. Special or Infrequent Service - As recommended by a qualified person before and after each occurrence.

PERIODIC INSPECTIONS - Periodic inspections are visual inspections by a designated person with interval per the following criteria.

1. Normal Service - Yearly
2. Heavy Service- Semi-Annually
3. Severe Service - Quarterly
4. Special or Infrequent Service- As recommended by a qualified person before the first occurrence.

D. FREQUENT INSPECTION:

Inspections should be made on a Frequent basis in accordance with Table 8-5, "Frequent Inspection." Included in these Frequent Inspections are observations made during operation for any defects or damage that might appear between Periodic Inspections. Frequent Inspections shall be made by a designated person to ensure that the hoist is maintained in safe working condition.

Table 8-5 Frequent Inspection
1. Check all functional operating mechanisms for maladjustment and unusual sounds.
2. Check the operation of the limit switch and associated components.
3. Check the hoist braking system for proper operation.
4. Check the hooks in accordance with ANSI/ASME B30.10.
5. Check the hook latch operation.
6. Check the Load Chain in accordance with Section 8B
7. Check the Load Chain reeving.

E. PERIODIC INSPECTION:

Inspections should be made on a Periodic basis in accordance with Table 8-6, "Periodic Inspection." Evaluation and resolution of the results of Periodic Inspections shall be made by a designated person to ensure that the hoist is maintained in safe working condition.



Periodic Inspection: For inspections where load suspension parts of the hoist are disassembled, a load test per ANSI/ASME B30.16 must be performed on the hoist after it is re-assembled and prior to its return to service.

Table 8-6 Periodic Inspection

1. Complete the requirements of Frequent Inspection.
2. Check to ensure there is no evidence of loose bolts, nuts or rivets.
3. Check to ensure there is no evidence of damage or excessive wear of load and idler sheaves.
4. Check to ensure there is no evidence of damage to hook retaining nuts or collars and pins, and welds or rivets used to secure the retaining members.
5. Check to ensure the warning label is properly attached to the hoist and legible.
6. Check to ensure the function labels on the pendant control stations are legible.
7. Check to ensure there is no evidence of worn, corroded, cracked or distorted parts such as load blocks, suspension housing, chain attachments, clevises, yokes, suspension bolts, shafts, gears, bearings, pins and rollers.
8. Check to ensure there is no evidence of damage to the supporting structure or trolley, if used.
9. Check to ensure there is no evidence of damage to the end connections of the load chain.
10. Check to ensure there is no evidence of excessive wear on motor or load brake.
11. Check to ensure there is no electrical apparatus for signs of pitting or any deterioration of visible controller contacts.

F. OCCASIONALLY USED HOIST:

Hoists that are infrequently used shall be inspected as follows before placing the hoist in service:

1. Hoist idle more than one month, less than one year: Inspect per Frequent Inspection.
2. Hoist idle more than one year: Inspect per Periodic Inspection.

G. INSPECTION REPORTS:

Hoists that are infrequently used shall be inspected as follows before placing the hoist in service:

1. A long range chain inspection program should be established and should include records of an examination of the chains that are removed from service. To create a relationship between visual observation and actual condition of the chain.
2. Dated inspection reports and records should be maintained for the hoist Periodic Inspection intervals. These records should be stored where they are available to personnel involved with the inspection, maintenance or operation of the hoist.

TROUBLESHOOTING:

Table 8-7 Troubleshooting Guide		
Symptom	Cause	Remedy
Hoist will not operate	Loss of power	Check circuit breakers, switches, fuses and connections on power lines/cable.
	Wrong voltage or frequency	Check voltage and frequency of power supply against the rating on the nameplate of the motor.
	Hoist overload	Reduce load to within rated capacity of hoist.
	Improper, loose or broken wire in the hoist electrical system	Shut off power supply, check wiring connections on hoist control panel and inside push button pendant.
	Brush wear	Inspect both motor brushes per Table 8-2 and replace if necessary.
	Fuses burned out	Replace fuses.
	Motor burned out	Replace motor frame/stator, shaft/rotor and any other damaged parts.
Hoist lifts but will not lower	Faulty switch in pendant	Check electrical continuity. Check electrical connections. Replace or repair as needed.
	Broken conductor in pendant cord	Check the continuity for each conductor in the cable. If one is broken, replace the entire cable.
Hoist lowers but will not lift	Hoist overload	Reduce load to within rated capacity of hoist.
	Worn friction clutch	Repair by a qualified person trained in the repair of hoists and proper friction clutch adjustment procedures. Replace as needed.
	Broken conductor in pendant cord	Check the continuity for each conductor in the cable. If one is broken, replace the entire cable.
	Faulty switch in pendant	Check electrical continuity. Check electrical connections. Replace or repair as needed
	Low voltage in hoist's power supply	Determine cause of low voltage and bring to within plus or minus 5% of the voltage specified on the motor nameplate. The voltage should be measured at the hoist contactor.
Hoist will not lift rated load or does not have the proper lifting speed	Hoist overload	Reduce load to within rated capacity.
	Low voltage in hoist's power supply	Determine cause of low voltage and bring to within plus or minus 5% of the voltage specified on the motor nameplate. The voltage should be
	Faulty friction clutch	If abnormal operation or slippage occurs do NOT attempt to disassemble or adjust the Mechanical Load Brake with Friction Clutch. Replace the worn or malfunctioning Mechanical Load Brake with Friction Clutch as an assembly with a new, factory adjusted part.
Load drifts excessively when hoist is stopped	Motor demagnetized	Motor demagnetizing is generally caused from using the hoist beyond its duty rating. Replace stator assembly and reduce usage to comply with the duty rating stated.
	Improper gear oil	Replace oil with the correct gear oil.
Hoist operates intermittently	Loose connection in circuit	Check all wires and terminals for bad connections. Replace as needed.
	Collectors making poor contact	Check movement of spring loaded arm, weak spring, connections and shoe. Replace as needed.
	Broken conductor in pendant cord	Check for intermittent continuity in each conductor in the pendant cord. Replace the entire pendant cord if continuity is not constant.

REPAIR PARTS ORDERING INSTRUCTIONS:

This parts and instruction manual contains information required to install and maintain your hoist. To insure prompt service, each repair parts order should be placed with an authorized distributor or OZ Lifting Products, LLC. Please visit the Replacement Parts Request form on our website.

www.ozliftingproducts.com/parts

Include the following information:

1. Serial number and model number located on the ID tag of the hoist.
2. Part name from the parts breakdown/parts list (see pg.22-25), or describe parts needed.
3. Quantity of parts requested.

Note: When ordering replacement parts, it is recommended that consideration be given to the need for also ordering such items as gaskets, fasteners, seals, etc. These items may be damaged or lost during disassembly or just unfit for future use because of deterioration from age or service.



Use of other manufactures' chain and parts to repair OZ Hoists is not recommended.

To avoid injury: Use only factory supplied replacement load chain and parts. Chain and parts may look alike, but factory original chain and parts are made of specific materials or processed to achieve specific properties.

WIRING DIAGRAM:

For OZ500EC

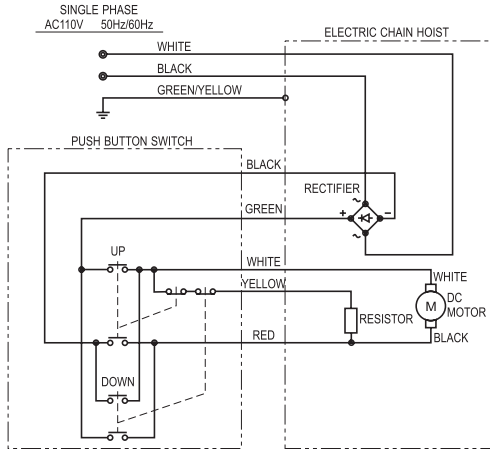

For OZ1000EC, OZ2000EC and OZ4000EC

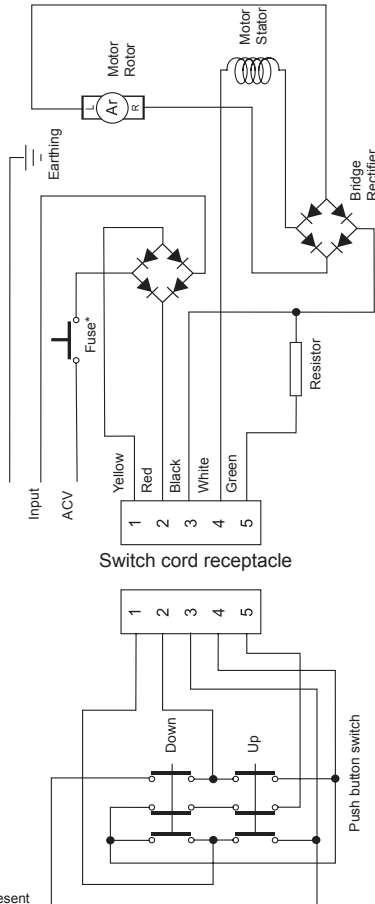

*Fuse may or may not be present

PARTS BREAKDOWN:

For OZ500EC

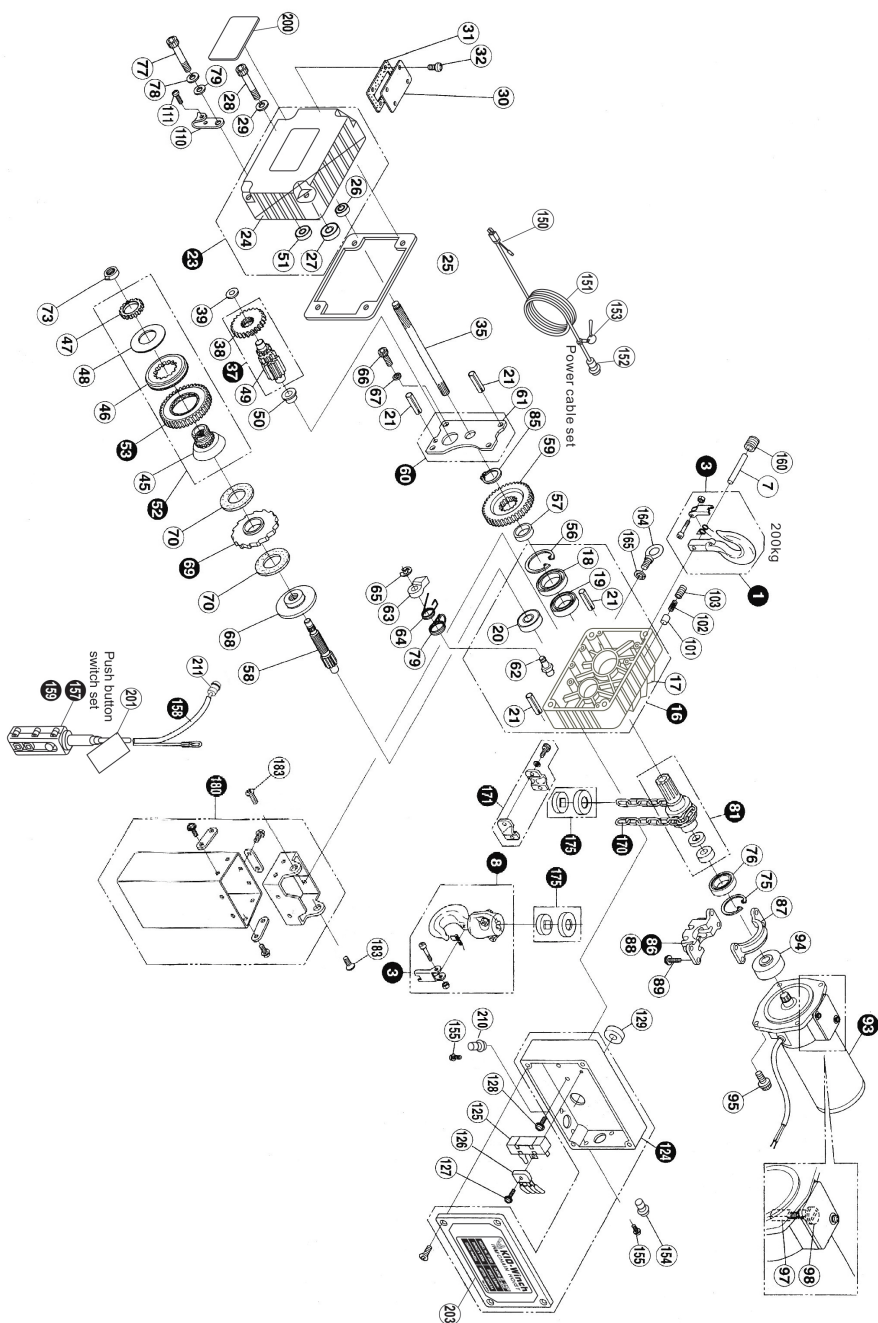

1	TOP HOOK ASS'Y
3	SAFETY LATCH ASS'Y
7	TOP HOOK PIN
8	BOTTOM HOOK ASS'Y
16	MAIN BODY CASE SET
17	MAIN BODY CASE
18	BALL BEARING
19	OIL SEAL
20	BALL BEARING
21	SPRING PIN
23	GEAR CASE ASS'Y
24	GEAR CASE
25	MAIN BODY CASE PACKING
26	BALL BEARING
27	BALL BEARING
28	BOLT W/HEX. HOLE
29	SPRING WASHERG
30	OIL CAP
31	OIL CAP PACKINGT
32	ROUND HEAD SCREW W/CROSS HOLER
35	1ST GEAR
37	2ND & 3RD GEAR ASS'YE
38	2ND GEAR
39	SIMRING
45	DISC HUB B
46	DISC HUB C
47	ADJUSTING NUT
48	DISC SPRINGE
49	3RD GEAR
50	BALL BEARING
51	BALL BEARING
52	FRICITION CLUTCH SET
53	4TH GEAR SET
55	C-CLIP (FOR HOLE)
57	COLLAR FOR SIXTH GEAR
58	5TH GEAR
59	6TH GEAR
60	MIDDLE PLATE SET
61	MIDDLE PLATE
62	PAWL PIN
63	PAWL
64	PAWL SPRING
65	E RING
66	BOLT W/HEX. HOLE
67	SPRING WASHER
68	DISC HUB A
69	RACHET WHEEL SET
70	BRAKE LINING
73	CHECK WASHER
75	C-CLIP (FOR HOLE)

76	BALL BEARING
77	BOLT W/HEX. HOLE
78	SPRING WASHER
79	PAWL SPRING B
81	LOAD SHEAVE SET
85	C-CLIP (FOR SHAFT)
86	CHAIN GUIDE SET
87	CHAIN GUIDE (UPPER SIDE)
88	CHAIN GUIDE (DOWN SIDE)
89	BOLT W/HEX. HOLE & WASHER
93	SINGLE PHASE MOTOR SET
94	MOTOR SHAFT JOINT
95	BOLT W/HEX. HOLE & WASHER
97	CARBON BRUSH
98	BRUSH CAP
101	LINING FOR MOTOR BRAKE
102	SPRING FOR MOTOR BRAKE
103	HEXAGON SOCKET SCREW
110	PUSH BUTTON HANGER FITTING
111	ROUND HEAD SCREW W/CROSS HOLE
124	ELECTRIC EQUIPMENT CASE SET
125	CEMENT RESISTOR
126	RECTIFIER
127	ROUND HEAD SCREW W/CROSS HOLE
128	ROUND HEAD SCREW W/CROSS HOLE
129	GROMMET
130	HARNES
131	HEX. NUT
150	POWER CABLE SET
151	POWER CABLE
152	POWER QUICK CONNECTOR (FEMALE)
153	SHACKLE
154	POWER CORD CONNECTOR QUICK CONNECTOR (MALE)
155	HEX. BOLT W/CROSS HOLE
157	PUSH BUTTON SWITCH SET
158	PUSH BUTTON CABLE SET
159	PUSH BUTTON SWITCH
160	HEXAGON SOCKET SCREW
164	EYE BOLT
165	SPRING WASHER
170	LOAD CHAIN
171	CHAIN STOPPER ASS'Y
175	BUFFER ASS'Y
180	CHAIN BAG ASS'Y
183	ROUND HEAD SCREW W/CROSS HOLE
200	NAME PLATE
201	WARNING TAG
203	TYPE NAME LABEL
210	PENDANT BODY CONNECTOR (MALE)
211	PENDANT CONNECTOR (FEMALE)

PARTS BREAKDOWN:

For OZ1000EC, OZ2000EC and OZ4000EC

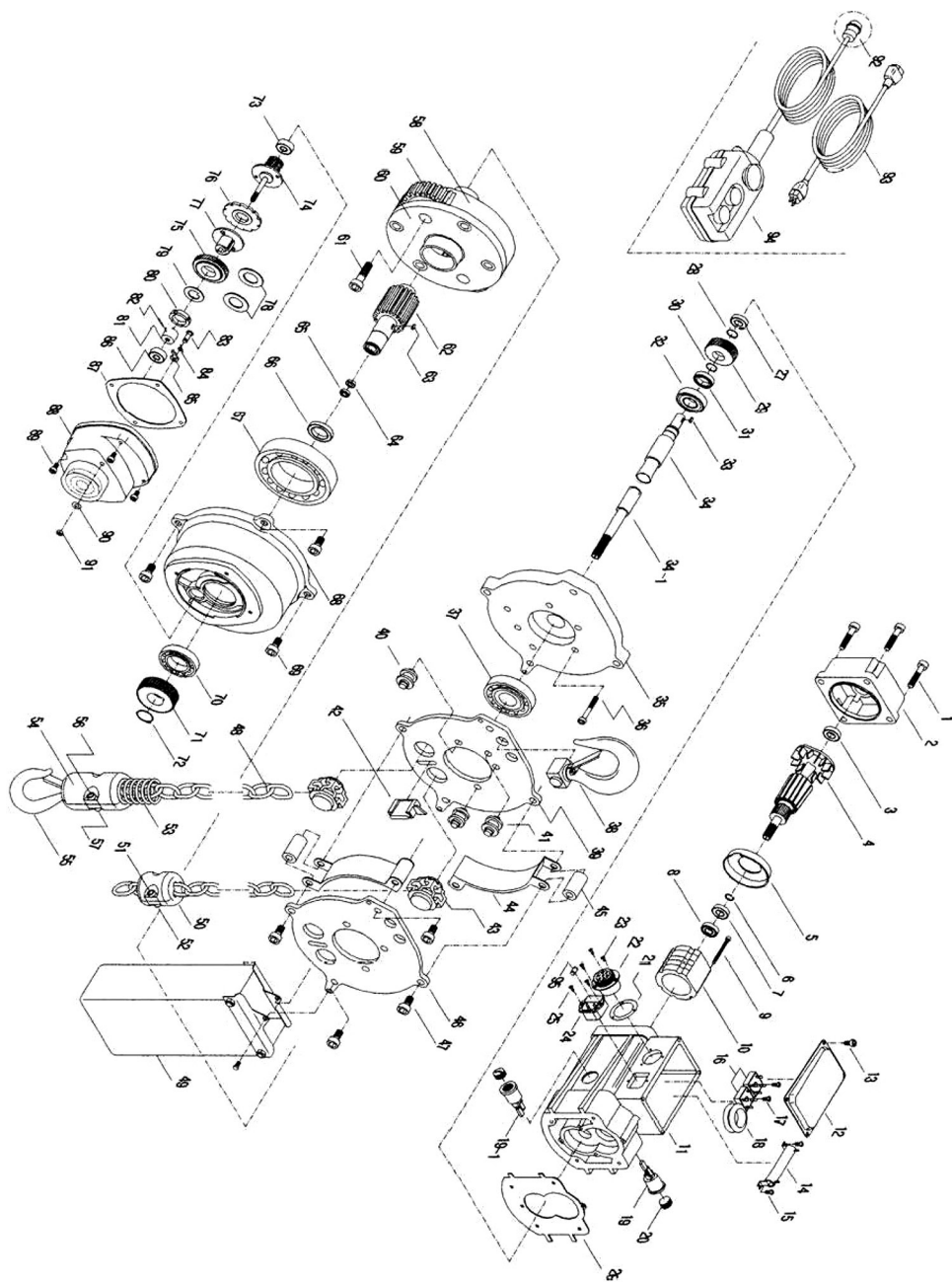

1	SCREWS
2	MOTOR COVER
3	BEARING
4	ROTOR
5	AIR GUIDING IRON COVER
6	FIXING SPRING
7	BEARING
8	OIL SEAL
9	SCREWS
10	STATOR
11	MAIN BODY BASE
12	WIRING BOX
13	SCREWS
14	RESISTOR
15	SCREWS
16	BRIDGE TYPE RECTIFIER
17	SCREWS
18	RUBBER BAND
19	BASE OF CARBON BRUSH
19-1	CARBON
20	CARBON BRUSH COVER
21	RUBBER WASHER
22	CONTROL CABLE SOCKET
23	SCREWS
24	POWER SUPPLY INPUT TERM
25	SCREWS
26	INSULATED SHEET
27	BEARING
28	FIXING SPRING
29	FIRST SECTION GEAR
30	FIXING SPRING
31	BEARING
32	BEARING
33	KEY
34	FIRST SECTION GEAR SHAFT
34-1	FIRST SECTION GEAR SHAFT
35	GEAR COVER
36	SCREWS
37	BEARING
38	UPPER HOOK
39	LEFT MAIN BODY SHEET
40	CHAIN GUIDING WHEEL
41	UPPER CHAIN GUIDING WHEEL
42	CHAIN PAWL DEVICE
43	CHAIN GUIDER
44	MAIN BODY COVER
45	FIXING ROD OF MAIN BODY
46	RINGH MAIN BODY SHEET
47	SCREWS

48	CHAIN
49	CHAIN BAG
50	CHAIN STOPPING BLOCK
51	SCREWS
52	NUTS, WASHER
53	CHAIN GUIDING SPRING
54	LOWER HOOK SUSPENSION
55	LOWER HOOK
56	SCREWS
57	NUTS, WASHER
58	CHAIN GUIDER
59	GEAR SHAFT
60	FIXING BASE OF GEAR SHAFT
61	SCREWS
62	THIRD SECTION GEAR SHAFT
63	KEY
64	OIL SEAL
65	BEARING
66	OIL SEAL
67	BEARING
68	GEAR REDUCE BOX OF SECOND LAYER
69	SCREWS
70	BEARING
71	THIRD SECTION GEAR
72	FIXING SPRING
73	BEARING
74	THIRD SECTION GEAR SHAFT
75	KEYLESS GEAR
76	PAWL BRAKE LINING
77	BRAKE DEPRESSOR (LOWER)
78	PRESS DISK TYPE SPRING
79	NUTS FIXING SHEET
80	TORQUE LIMITED NUTS
81	BRAKE DEPRESSOR (UPPER)
82	FIXING PIN
83	CLICK FIXING BOLT
84	CLICK SPRING
85	CLICK
86	PRESS DISK TYPE SPRING
87	PACKING
88	FIRST LAYER GEAR BOX
89	SCREWS
90	WASHER
91	NUTS
92	CONTROL PLUG
93	POWER CABLE SET
94	CABLE SET OF CONTROL SWITCH
95	FUSE



P.O. Box 845, Winona, MN 55987
Phone (800) 749-1064
(507) 474-6250
Tech Support (507) 457-3346
Fax (507) 452-5217
sales@ozliftingproducts.com
www.ozliftingproducts.com

