

Cluster Swivel Booth Seat Instructions

www.nationalpublicseating.com

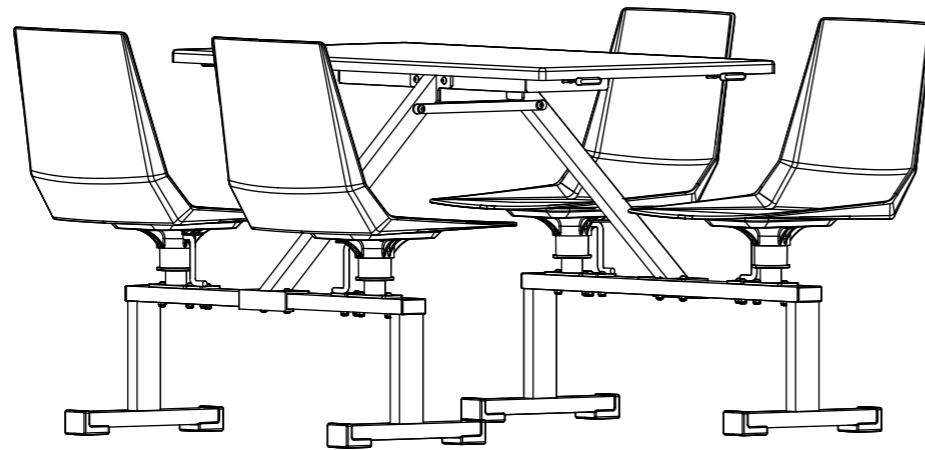

Parts List

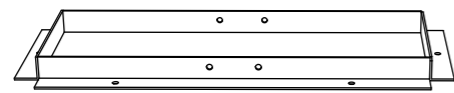

Ⓐ Table frame x 1

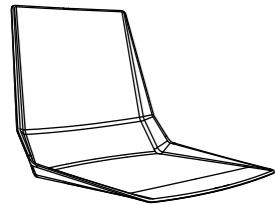

Ⓑ-1. Seat x 4

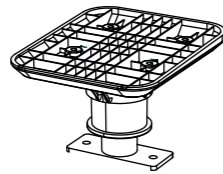

Ⓑ-2. Seat base x 4

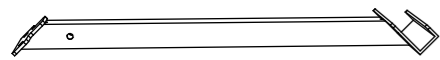

Ⓒ Connecting frame x 2

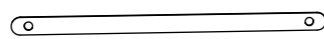

Ⓓ Connecting plate x 2

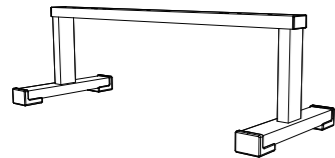

Ⓔ Seat frame x 2



Ⓕ Swivel control-L x 2



Ⓖ Swivel control-R x 2

Accessory Tool

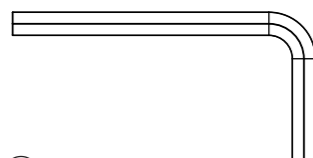

Ⓗ Hex key

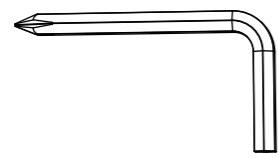

Ⓘ Phillips wrench



Ⓙ Open end wrench

Hardware List

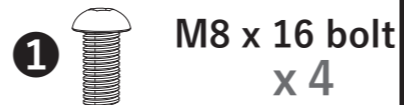

Ⓛ M8 x 16 bolt x 4

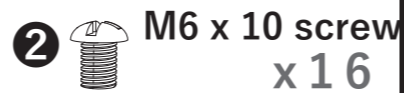

Ⓜ M6 x 10 screw x 16

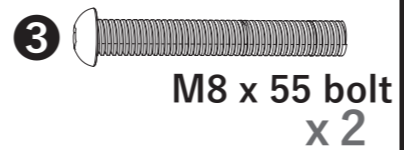

Ⓝ M8 x 55 bolt x 2

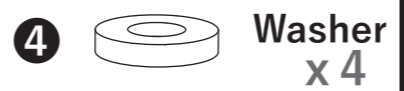

Ⓟ Washer x 4

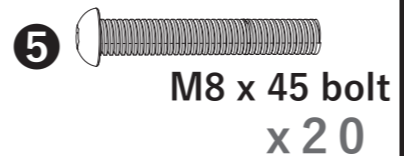

Ⓡ M8 x 45 bolt x 20



Ⓡ Nut x 26

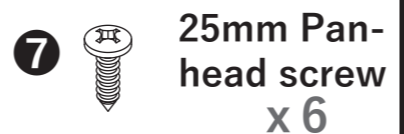

Ⓡ 25mm Pan-head screw x 6

Floor connection optional parts



Ⓢ Fastening plate x 4



Ⓣ Expansion bolt x 4



Ⓤ Screw x 4

1 Install table frame Ⓐ to tabletop as follows: Begin by aligning the six frame holes over pilot holes on underside of tabletop. Using the six 25mm pan-head screws Ⓡ, tightly fasten screws to tabletop.

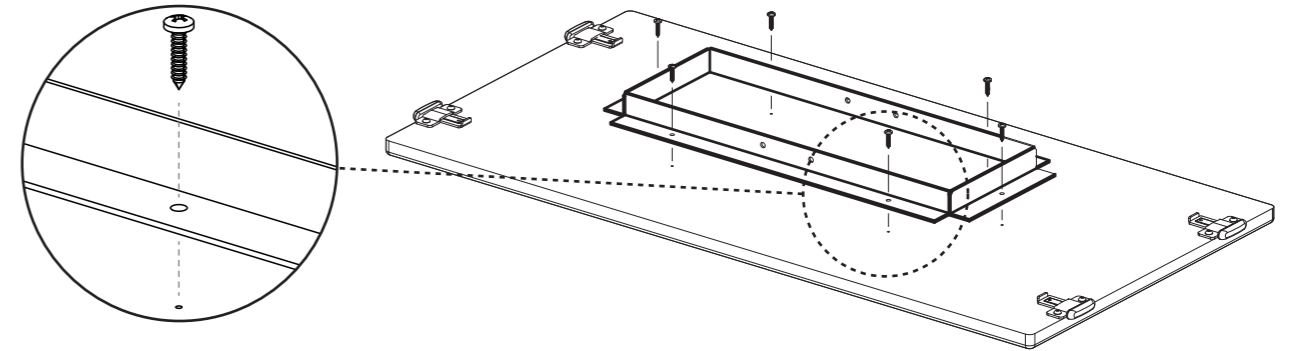

2 Align the holes on the flat side of two connecting frames Ⓒ with the holes on the table frame Ⓐ. Insert four M8 x 16 bolts Ⓛ and tighten with four nuts Ⓡ using enclosed hex key Ⓗ and open end wrench Ⓙ. *Don't fully tighten the bolts until you make sure that the main structure is level with the ground at step 4.

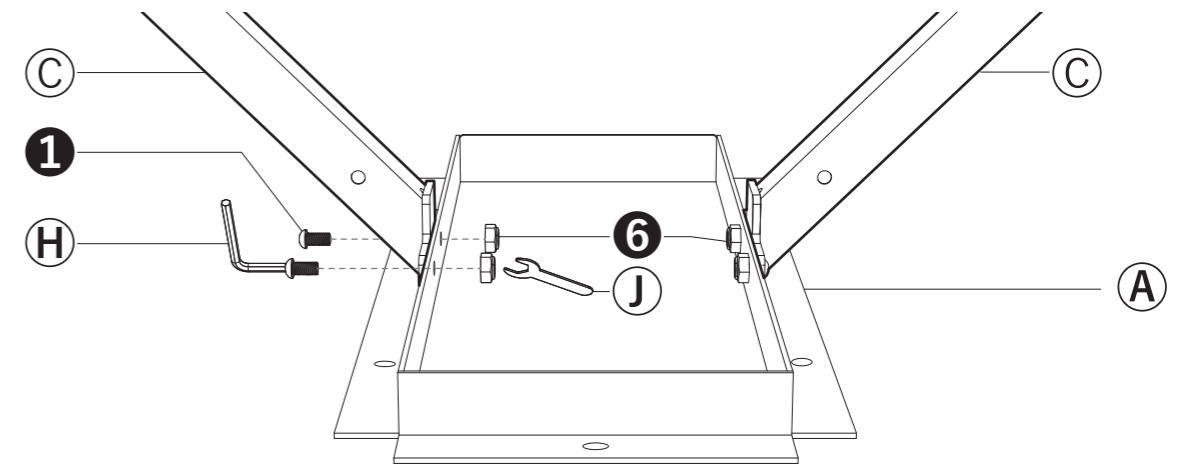

3 Align the holes on two connecting plates Ⓓ with the holes on two sides of connecting frames Ⓒ. Insert two M8 x 55 bolts Ⓝ through four washers Ⓟ and tighten with two nuts Ⓡ using enclosed hex key Ⓗ and open end wrench Ⓙ. *Don't fully tighten the bolts until you make sure that the main structure is level with the ground at step 4.

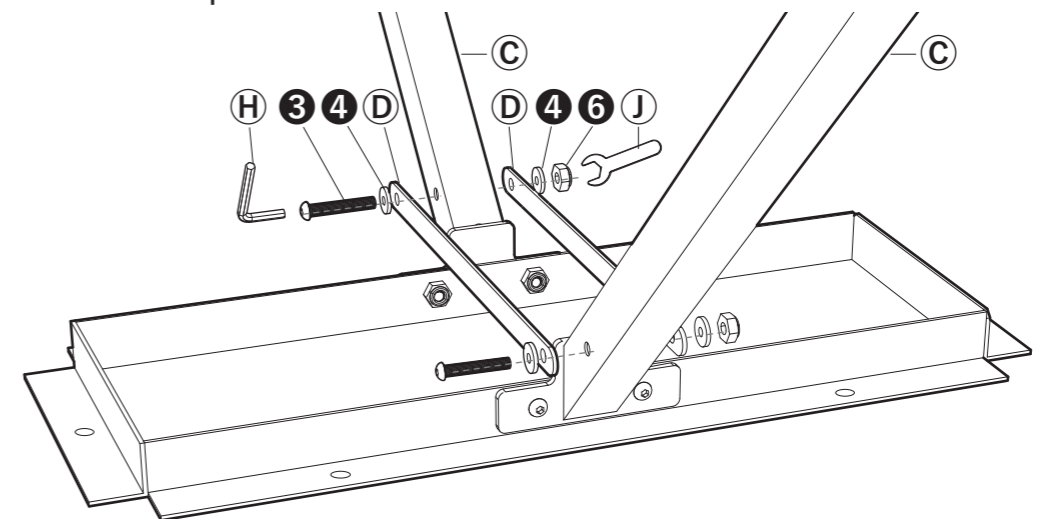

For unit with optional floor connectors- Step 1

Place seat frame **E** on a flat and clean surface. Align the hole on fastening plate **8** as the direction shown below with hole at the bottom of seat frame. Insert screw **10** and tighten it using enclosed Phillips wrench **1**.

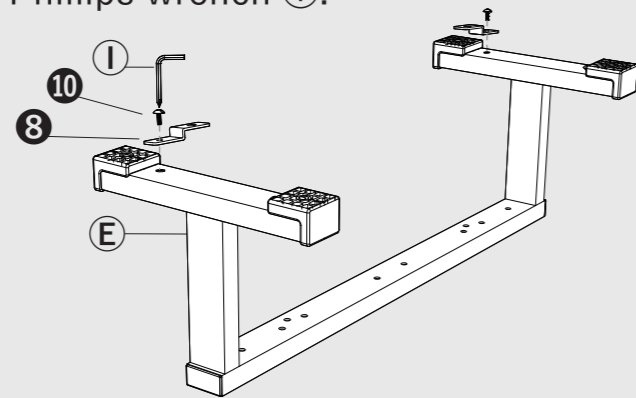

4 Fasten seat frame **E** into the mouth of connecting frame **C**. After aligning holes to holes on seat frame, insert two M8 x 45 bolts **5** and tighten with two nuts **6** using enclosed hex key **H**.

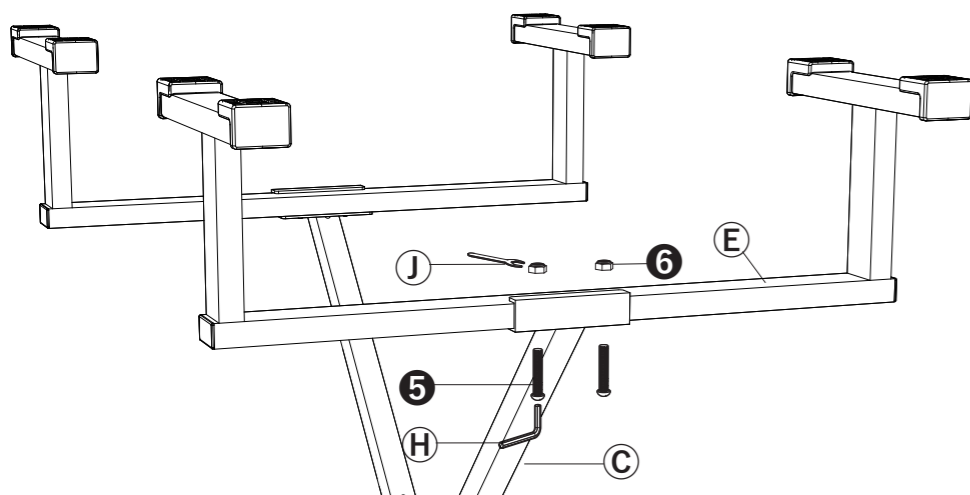

※For optional floor connection, make sure that fastening plate should be placed backward.

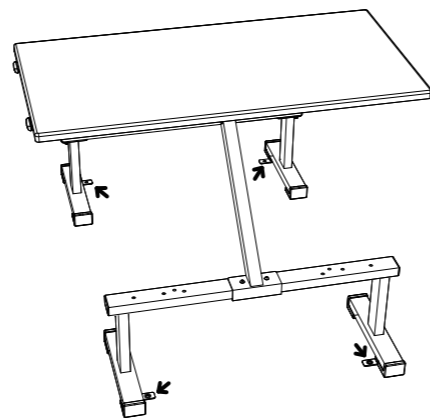

5 Make sure that four legs touch the ground evenly and then tighten the bolts within Step 1 and 2.

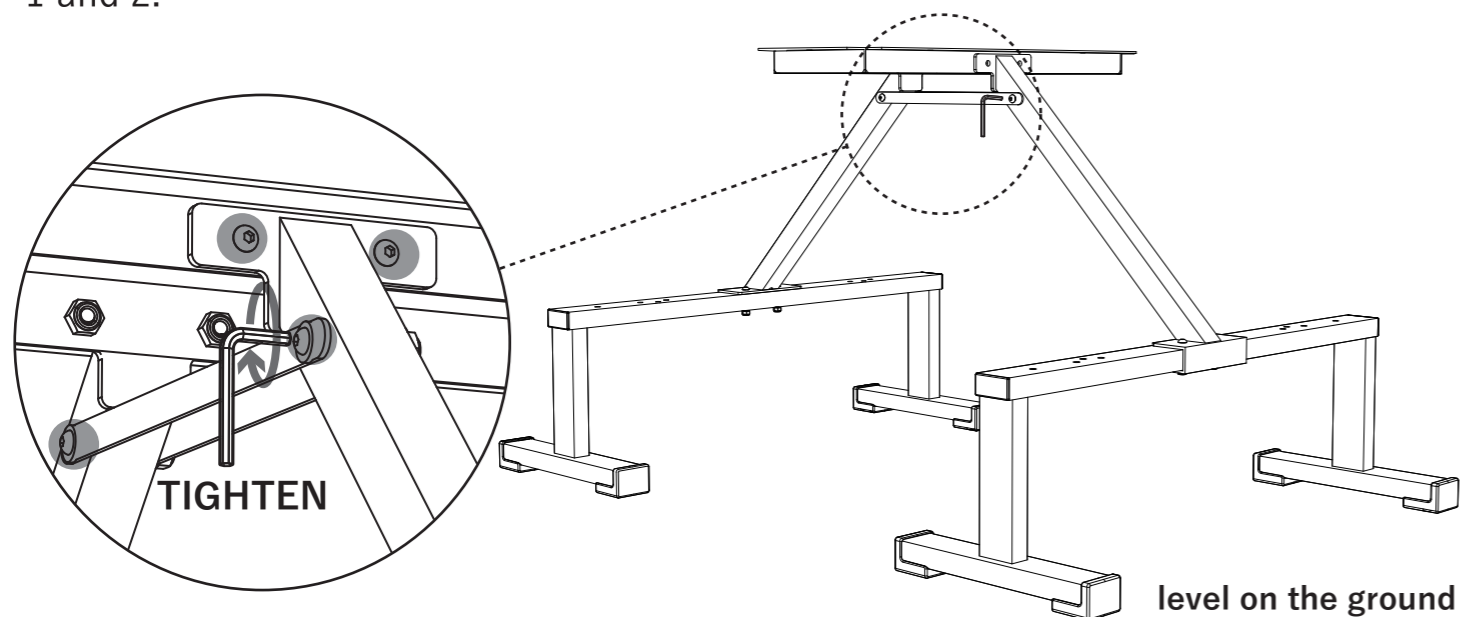

6

Place seat **B-1** downward on a flat and clean surface. Note that the arrow on seat base **B-2** should point forward. After aligning the holes, insert four M6 x 10 screws **2** and tighten them using enclosed Phillips wrench **1**.

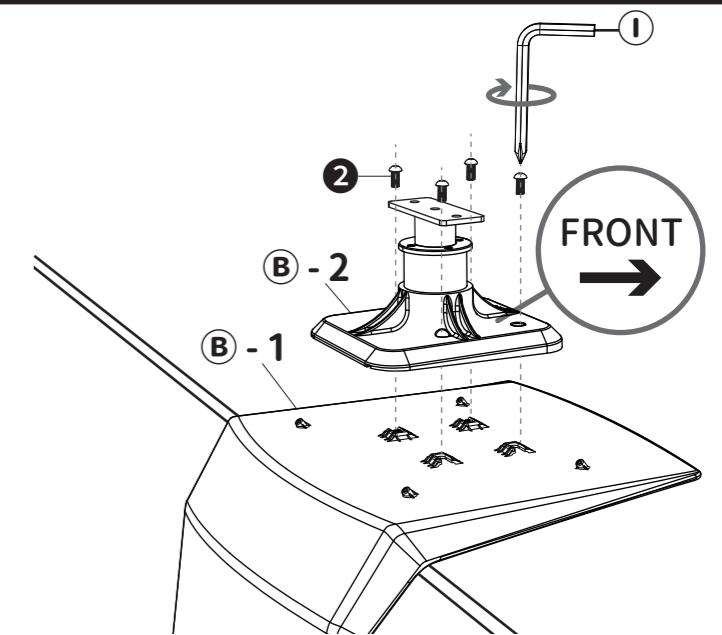

7

Align the holes on seat bases **B** with the holes on seat frames **E**. Insert two M8 x 45 bolts **5** and tighten with two nuts **6** using enclosed hex key **H** and open end wrench **J**.

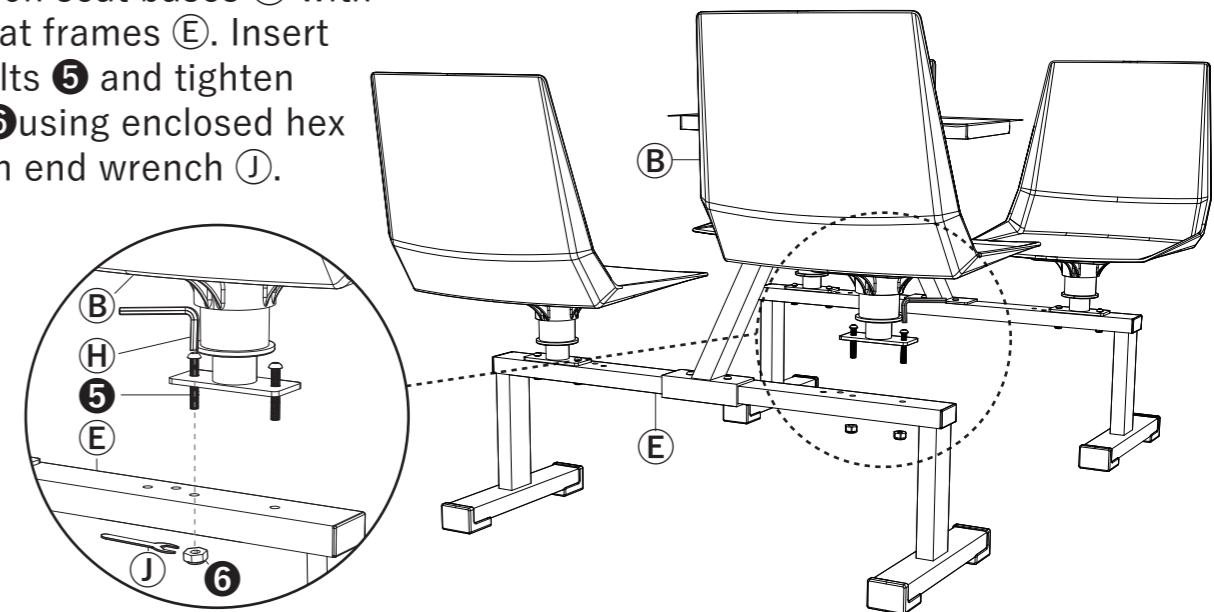

Optional Swivel control

Turn seat **B** straight ahead. Place swivel control-L **F** at the left hand side and swivel control-R **G** at the right hand side and align the holes to holes on seat frame **E**. Insert two M8 x 45 bolts **5** and tighten with two nuts **6** using enclosed hex key **H** and open end wrench **J**. Rotate the seats to make sure all of them turn outward.

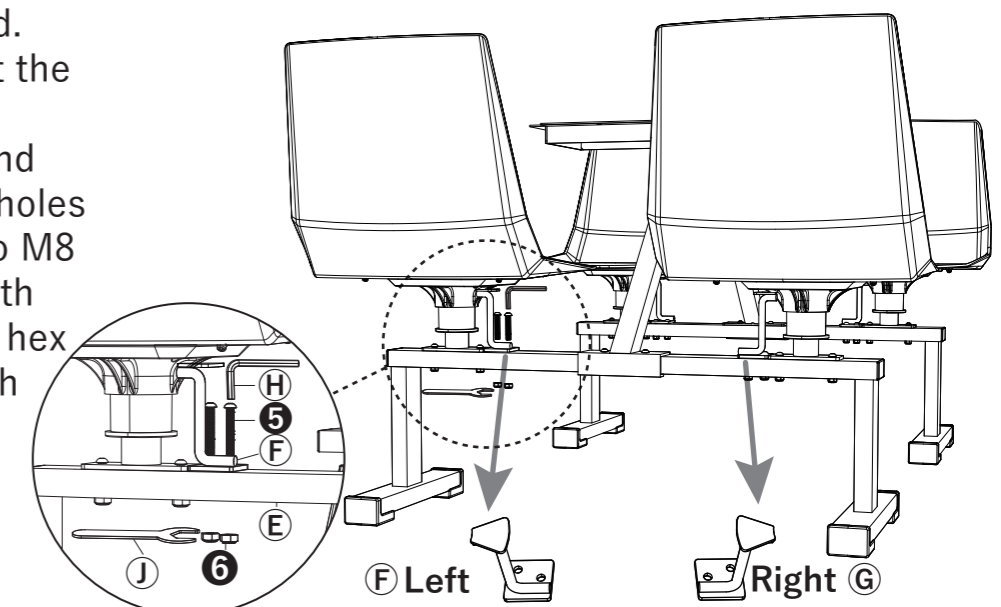

Recommended items for unit with optional floor connectors.

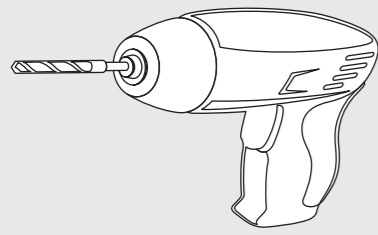

Ⓚ Electric drill
3/8 drill bit

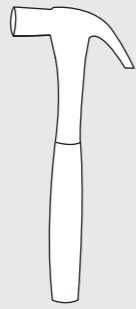

Ⓛ Hammer



Ⓜ Dust blowing ball



Ⓝ Pencil



Ⓞ Wrench

Follow below steps for for unit with optional floor connectors.

Optional floor connection-Step 2

After placing the cluster swivel booth to the position where you are going to fix, mark four holes of fastening plate 8 by pencil ③ on the floor.

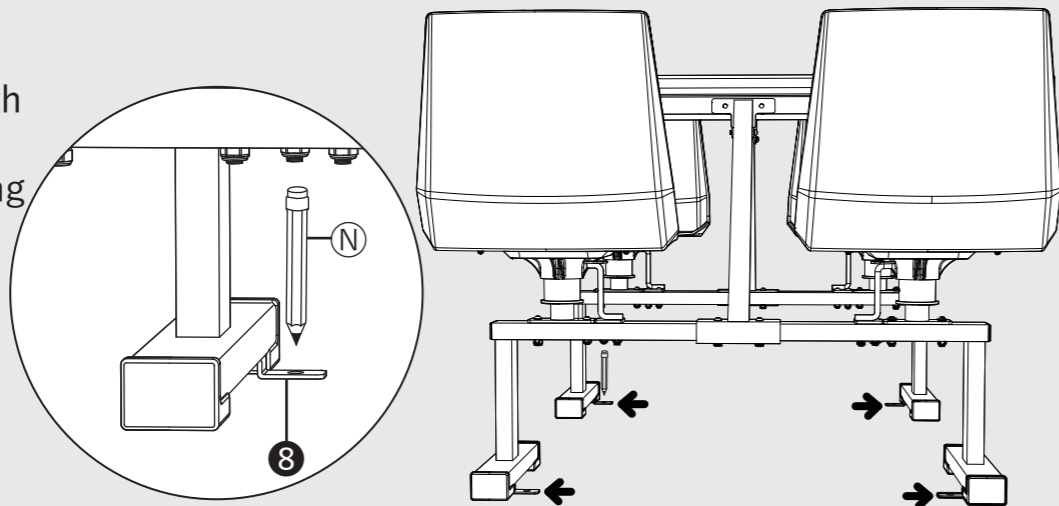

Optional floor connection-Step 4

Align the holes on fastening plate 8 with the holes on the floor. Knock expansion bolt 9 into the hole using hammer ④.

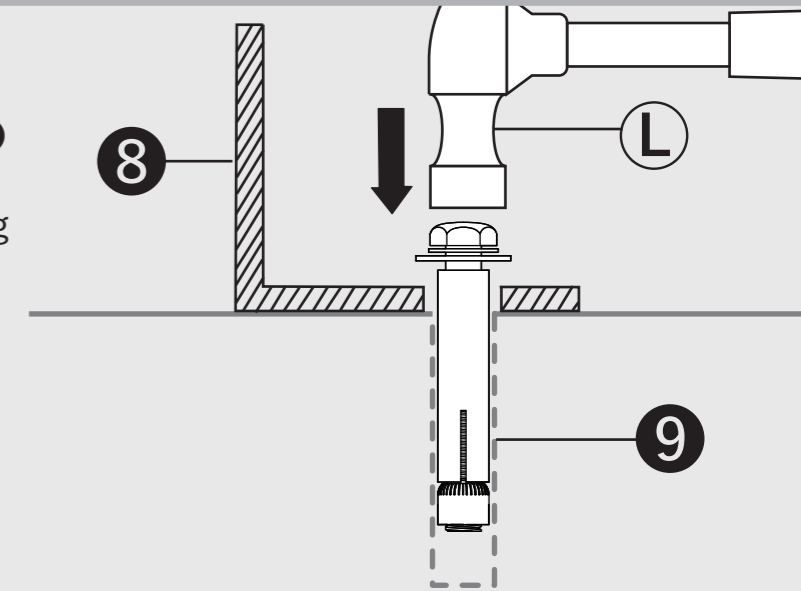

Optional floor connection-Step 5

Tighten expansion bolt 9 using wrench ⑤ to fix fastening plate 8 on the floor.

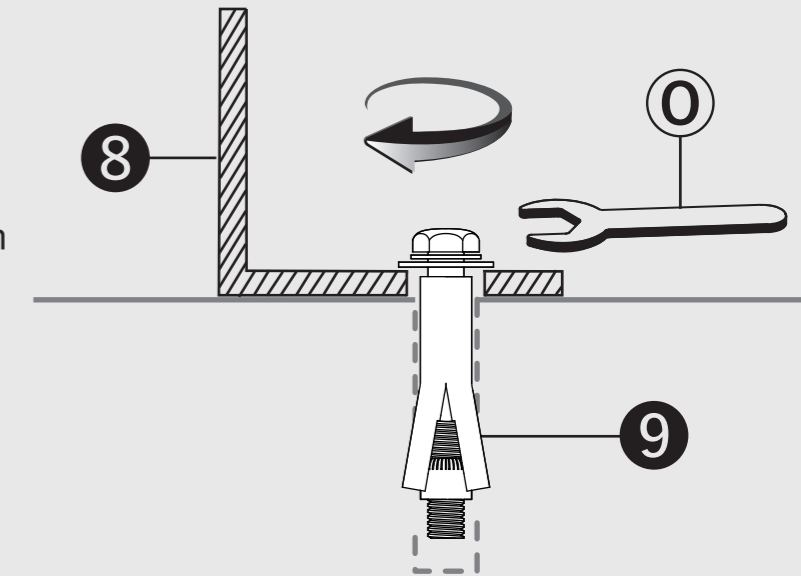

Optional floor connection-Step 3

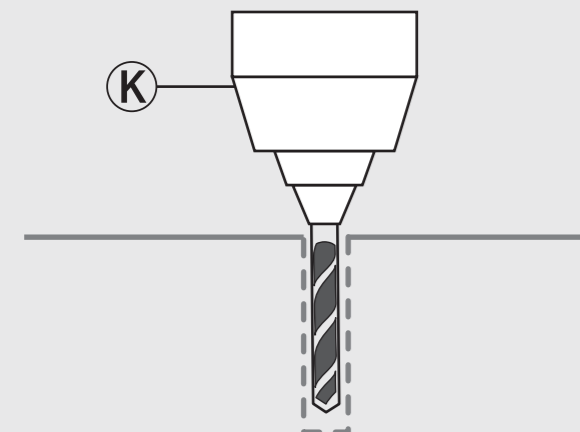

Drill the marked holes using electric drill ④ with 3/8 drill bit to a depth of 75mm.。

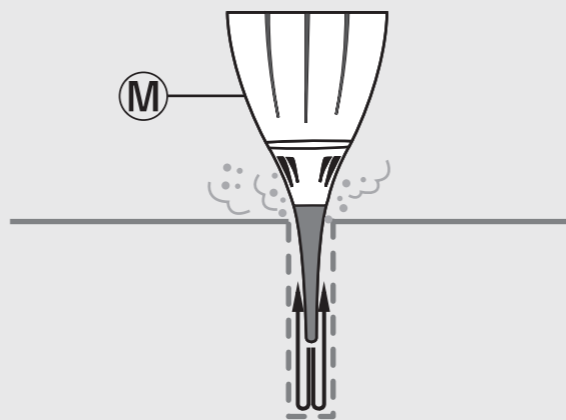

After drilling, clear out the dust from the holes using dust blowing ball ⑤.

Optional floor connection-assembly completed

