

(CARRIAGE ASSEMBLY)

REPLACEMENT PARTS LIST			
ITEM	PART NO.	DESCRIPTION	QTY.
1	056400	JACK: STAINLESS ASS'Y (40")	1
2	056472	WELDMENT: JACK/CARRIAGE	1
3	109452	CASTER:SWIVEL, 5X2, SS	2
4	109453	FLOOR LOCK: 304SS	1
5	109454	WHEEL: 5X2 PHENOLIC	2
6	056390	DRUM GRAB AUTOMATIC - S.S.	1
7	056481	ROLLER: CARRIAGE (SSDH)	6
8	109491	WASHER: SS, 1/2"ID, 1-1/4"OD	12
9	109492	RING:RETAINING, SS, 1/2"	6
10	109528	SCREW: SS, TRUSS HD (10-32 X 1/2)	1
11	056478	ASSEMBLY: LIFT CABLE	1
12	056479	GUARD:"WESCO" SSDH	1
13	109527	NUT: SS, HEX NYLOCK, #10-32	4
14	109499	MAGNET: STAINLESS ENCASED	2
15	108944	RING: CIRCLE, COTTER PIN	1
16	056480	PIN: ADJUSTMENT (SSDH)	1
17	108226	HANDGRIP: 1" BLACK PVC	2
18	056539	SHEAVE: SS, 1/4" WIRE ROPE	1

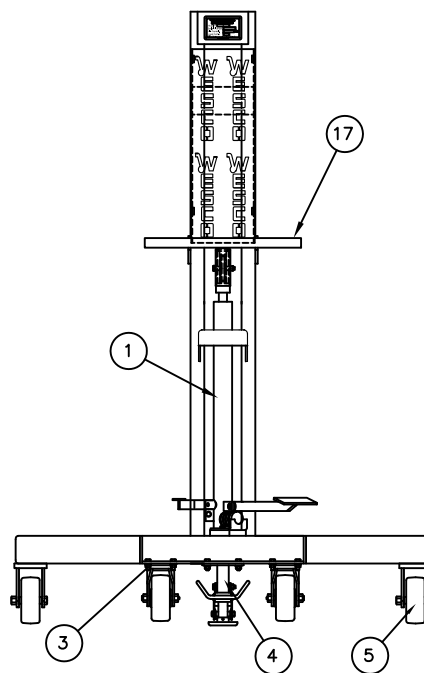
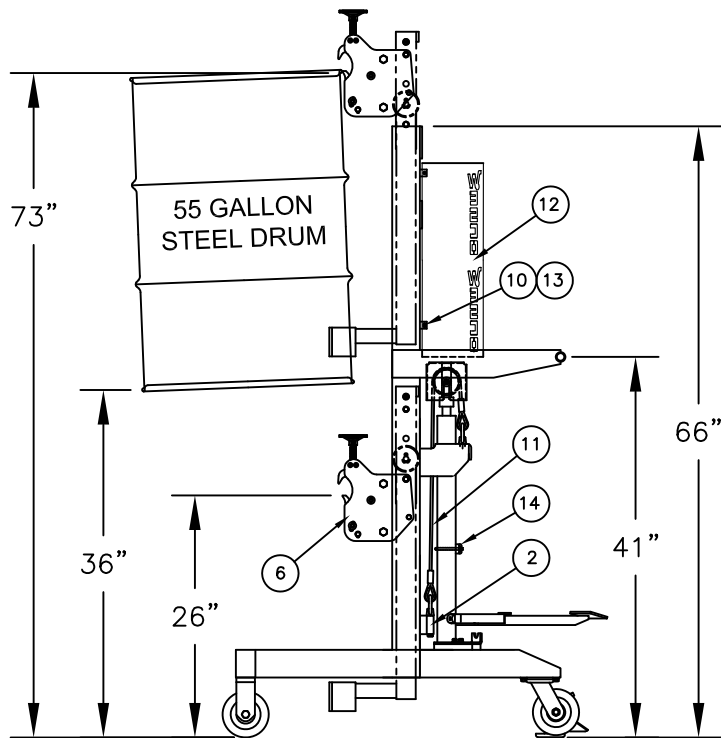

**304 Stainless Steel High Reach**

- The Wesco Stainless Steel Drum Handler has a stainless steel frame, platform and hydraulic jack with:
  - Phenolic wheels with stainless frame and bearings.
  - Stainless steel caster rig and bearing with phenolic wheel
  - Stainless steel hydraulic pump with copper pumping cylinder and copper sealing ring.
  - Stainless steel wire rope assembly with zinc plated copper compression sleeve.
  - Stainless steel wire rope sheave with bearing bronze bushing.
  - ABS plastic cable guard.
  - PVC hand grips.
- Works with most drums with locking rings.
- Lift range: 26" - 73" at lifting clamp.
- Single position outriggers - non-telescoping.
- Handles most 30, 55 and 85 gallon steel poly drums.

Specs  
 Rise/Stroke: 1"  
 Capacity: 800 lbs  
 Drum Clamp Type: Manual Knob Lock  
 Weight: 207 lbs

PRINT ISSUED  
 APR 01 2015  
 WESCO MANUFACTURING  
 ENGINEERING DEPARTMENT

THIS DRAWING IN ALL PARTICULARS IS WESCO INDUSTRIAL PRODUCTS INC. PROPERTY. ALL RIGHTS OF DESIGN, INVENTION OR USE OF ARE RESERVED.

REV. 1		WESCO INDUSTRIAL PRODUCTS INC. NORTH WALES PENNA. 19454	
REV. 2	PART NAME	SSDH	DRAWN:
	STAINLESS STEEL DRUM HANDLER		CHECKED:
	TOLERANCE UNLESS OTHERWISE SPECIFIED		APP. ENR.
	FRACTION	3 PLACE DECIMAL	2 PLACE DECIMAL
	± 1/64	± .005	± .01
	ANGULAR ± 1-1/2°	SHEET 1	OF 1
BREAK ALL SHARP EDGES AND REMOVE ALL BURRS.			
C-240240			2 B