

Parts List

Quantity	Description
1	Plastic Box (with 16 Clearance Holes)
16	5/16-18 X 3/4" Lg. Hex Head Bolt
16	5/16 Standard Plated Washer
16	5/16-18 Plated Hex Jam Nut
2	Fixed Caster with 5" Diameter Wheels
2	Swivel Caster with 5" Diameter Wheels

Installation

- 1) Position a fixed caster's mounting plate on the outside, bottom part of the plastic box, aligning it's holes with any 4 patterned holes in the box.
- 2) Insert a round head machine screw through the inside, bottom part of the box and through a hole in the fixed caster's plate.
- 3) Insert a washer over the screw.
- 4) Assemble the jam nut finger tight.
- 5) Repeat steps 2 through 4 to assemble the remaining 3 screws to the caster.
- 6) Wrench tighten the 4 nuts.
- 7) Install the second fixed caster on the same, narrow side of the box as the first caster (repeating steps 1 through 6).
- 8) Install the 2 remaining swivel casters at the opposite, narrow end of the plastic box in (the same manner as the fixed casters).

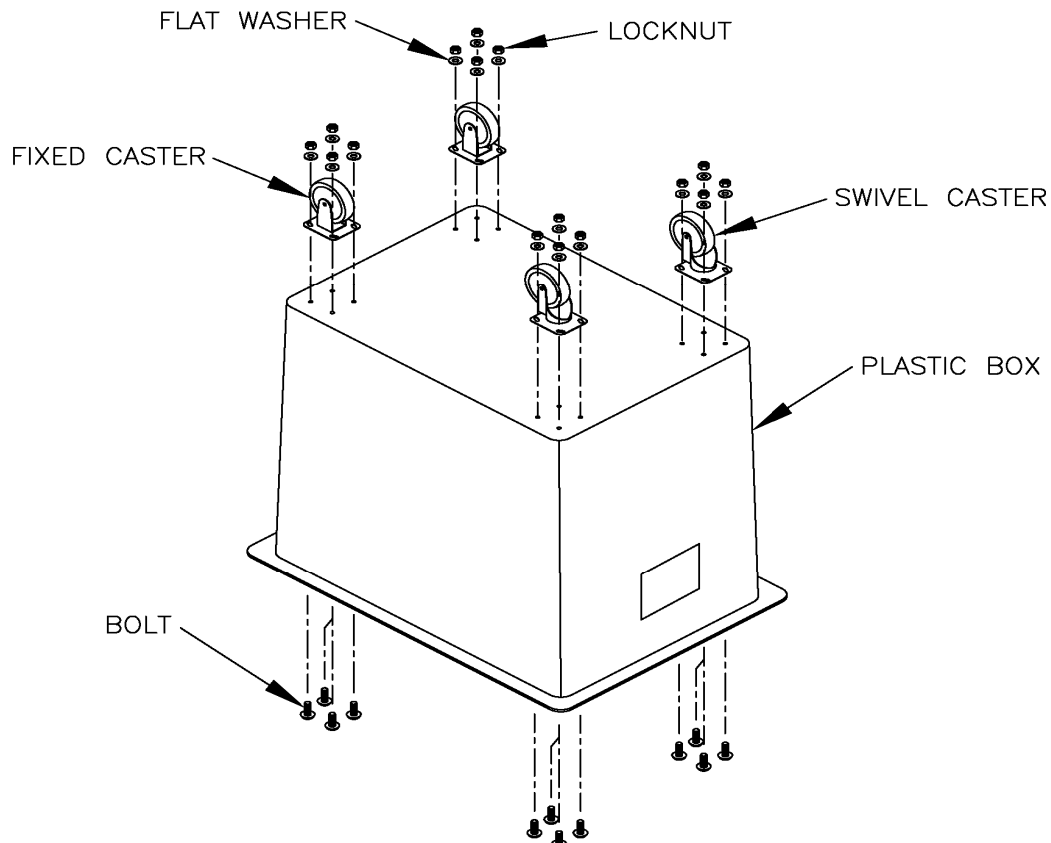

Figure 1