



# INDUSTRIAL WORKBENCH With Steel Top

Tennsco Corp., Dickson, TN 37056-1888 • (615) 446-8000

## RETAIN INSTRUCTIONS FOR FUTURE REFERENCE!



Congratulations on your purchase of a Tennsco Workbench! Tennsco's workbenches are ideally suited for factories, shops, labs, garages, and more.

Your workbench features a 12-gauge steel top, formed into a 1 1/2-inch tall channel formation. Duplex holes punched into the workbench legs may be utilized to provide power to your workbench. The holes are designed to receive a Steel City electrical box, Model #CDOW (2.5" x 2" x 3").

Some additional options that are available for your bench include stackable drawers with an optional lock, a lower shelf, adjustable legs, side and back rails, a riser, and an electronic riser. The parts list on the back of these instructions provide part numbers for these accessories.

**PLEASE NOTE:** These instructions are for a workbench with flared or adjustable legs. If you have ordered a modular workbench (with modular door or drawer units instead of legs) please disregard these instructions and assemble using the instructions that came with your modular units.

**GENERAL SAFETY INFORMATION:** Some parts may have sharp edges. CARE must be taken when handling various pieces to avoid injury. For safety, wear a pair of work gloves when assembling or performing any maintenance on your workbench.

### LIMITED WARRANTY

Tennsco warrants goods purchased hereunder to be free of defects in materials and workmanship for a period of one (1) year from the date of shipment, hereunder. This warranty shall not apply in the event goods are damaged as a result of misuse, abuse, neglect, accident, improper application, modification or repair by persons not authorized by Seller, where goods are damaged during shipment, or where the date stamps on the goods have been defaced, modified or removed. UNLESS CONSIDERED UNENFORCEABLE OR UNLAWFUL UNDER APPLICABLE LAW:

- a. ALL IMPLIED WARRANTIES, INCLUDING BUT NOT LIMITED TO WARRANTIES OR MERCHANTABILITY AND FITNESS FOR A PARTICULAR PURPOSE ARE HEREBY EXCLUDED:
- b. BUYERS REMEDY, IF ANY, FOR ANY DEFECTIVE GOODS SHALL BE LIMITED TO A REFUND BY SELLER OR REPLACEMENT OF THE GOODS AT SELLER'S OPTION, AND SHALL IN NO EVENT INCLUDE DAMAGES OF ANY KIND, WHETHER INCIDENTAL, CONSEQUENTIAL OR OTHERWISE.

NO GOODS ACCEPTED FOR RETURN WITHOUT PRIOR APPROVAL. Seller shall have the right to inspect any goods claimed to be defective at Buyer's place of business or require Buyer to return the goods to Seller for inspection on Seller's premises. Transportation charges covering returned goods will be borne by Seller only if such goods are proven to be defective, are covered by this warranty and are returned within the warranty period stated above.

TENNSCO Corp., P.O. BOX 1888, DICKSON, TN 37056-1888  
(615) 446-8000 or (866) 446-8686 (toll free)  
Website: [www.tennsco.com](http://www.tennsco.com) E-mail: [Info@tennsco.com](mailto:Info@tennsco.com)

# ASSEMBLY OF INDUSTRIAL WORKBENCH

Tools Needed: A phillips-head screwdriver and a  $\frac{7}{16}$ " wrench or nut driver.  
Approximate assembly time for basic bench: 15 to 25 minutes.

- Place the workbench top (Ref. No. 1) upside down on two sawhorses or a flat surface. Locate two mounting

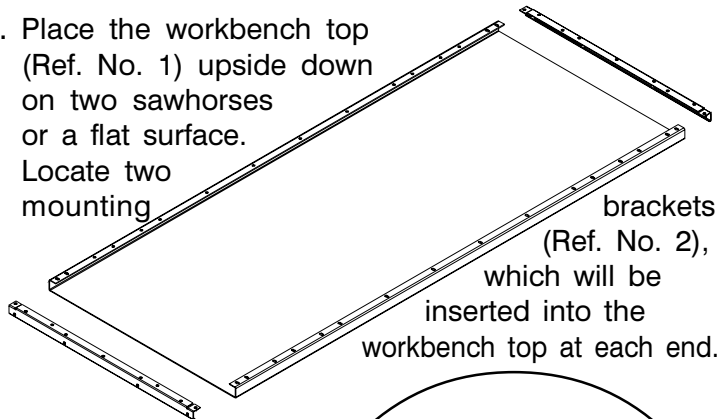

brackets (Ref. No. 2), which will be inserted into the workbench top at each end.

- Insert a mounting bracket into one side of the top. Make sure that the side with the most holes is facing up, and that the open end is facing into the top. The holes in the top of the bracket ends will align with the last holes in the workbench top.

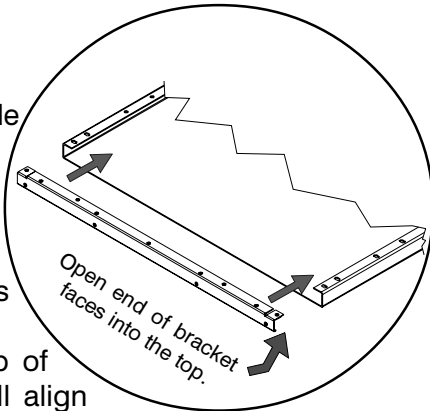

- Place a workbench leg (Ref. No. 3) on the top, aligning the four end holes as shown below. Attach it by first threading two  $\frac{1}{4}$ "-20 x  $\frac{5}{8}$ " bolts (Ref. No. 18) through the leg, the top, and into the welded nuts on the mounting bracket. Then insert two more bolts through the leg and top, and secure with two  $\frac{1}{4}$ "-20 nuts (Ref. No. 19). Attach the other leg in the same way.

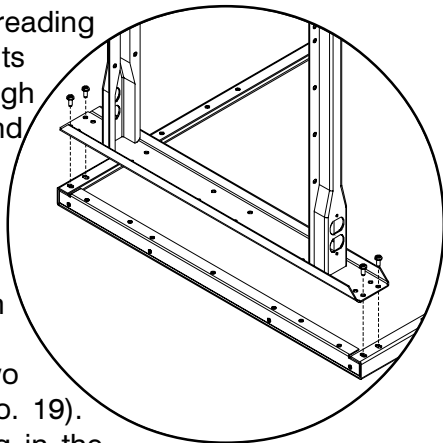

**NOTE:** The drawings throughout this instruction sheet show the flared leg. If your bench came with adjustable legs, the legs will look different than the drawings shown throughout these instructions. The drawing shown here illustrates an example of both leg styles: the flared leg (shown at left) and the adjustable leg (shown at right).

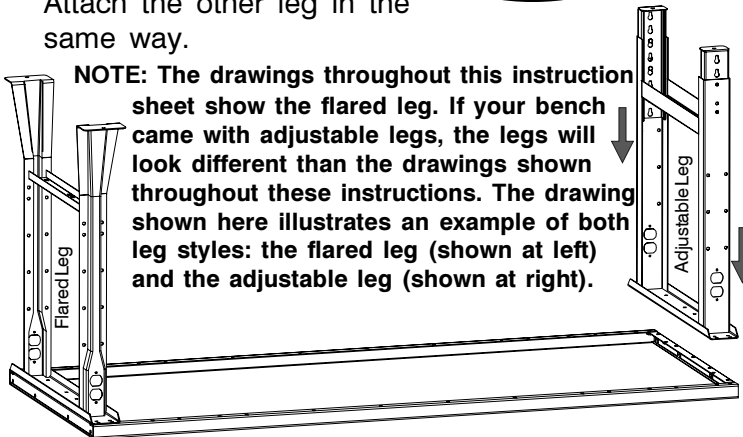

- The two remaining mounting brackets are used either for additional desktop support, or to mount a workbench drawer. If you are adding the drawer to your bench, skip to step 5. Otherwise, attach the two remaining mounting brackets under the lip of the bench top for extra support, using one bolt on each end of each bracket. The brackets should be evenly spaced for maximum support.

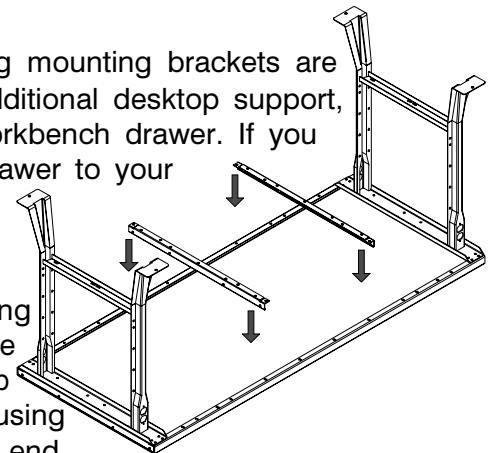

- Attach the stringer (Ref. No. 4) to the rear legs, skipping the top two holes and using the next four holes from the top of each leg. (The legs are symmetrical, so the front and rear of the bench will be determined by where you place the stringer.) Attach with eight bolts, nuts, and lockwashers.

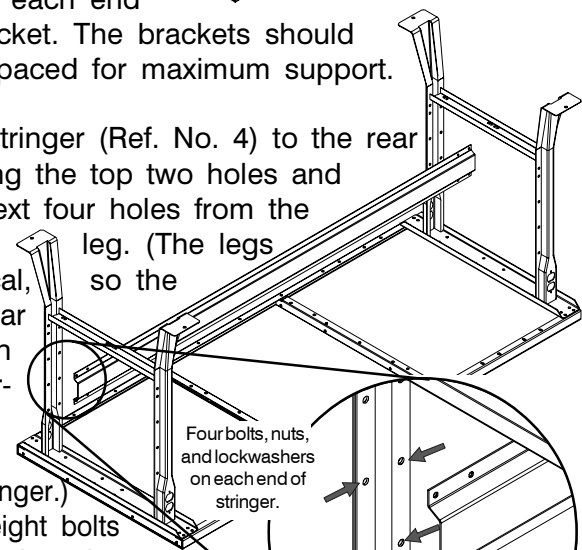

**NOTE:** The stringer attaches to the flat area of the leg. For flared legs, this will be on the inside of each leg; for adjustable legs, this will be on the outside of each leg (see the illustrations at right).

Flared Leg: stringer attaches to inside of leg

Adjustable Leg: stringer attaches to outside of leg

- If you purchased only the basic workbench, your bench is now complete. The remaining instructions show assembly of optional accessories (such as the workbench drawer, the lower shelf, side and back rails, or risers).

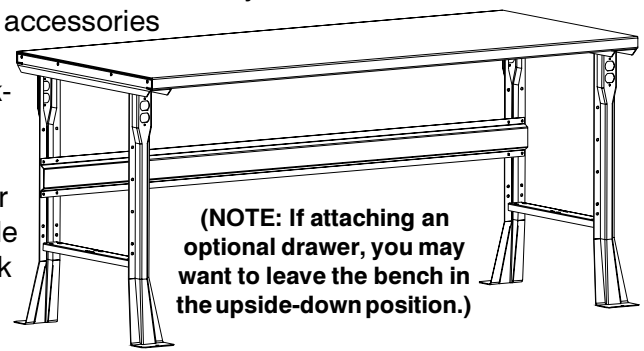

(NOTE: If attaching an optional drawer, you may want to leave the bench in the upside-down position.)

# OPTIONAL ACCESSORIES

## Optional Workbench Drawer

1. Remove the drawer (Ref. No. 6) from the drawer housing (Ref. No. 7)

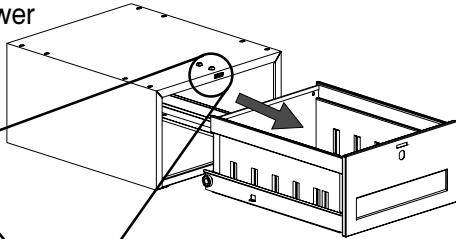

2. If using a padlock, place the lock hasp (Ref. No. 8) onto the two bolts which extend down from the drawer housing. Attach using two  $1/4$ "-20 nuts. Remove the rectangular knock out panel on drawer front.

3. Attach the two remaining mounting brackets (referred to in step 4 on the previous page) in the desired location on the workbench top. It is most common to place the drawer to either the far left or far right side of the bench, but the drawer can be placed anywhere where there are two holes in the bench top that are 15" apart. Secure with two  $1/4$ "-20 x  $5/8$ " bolts per mounting bracket.

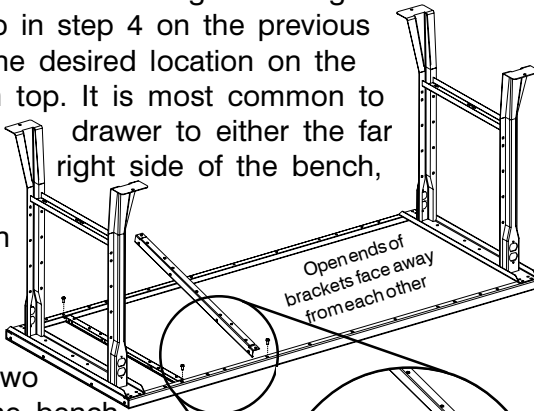

4. Attach the drawer housing to the mounting brackets. Secure with four  $1/4$ "-20 x  $5/8$ " bolts.

5. To install optional cam lock (Ref. No. 11), punch out the round knock-out panel in the drawer front. Then insert the cam lock through the hole, and secure with forked clip.

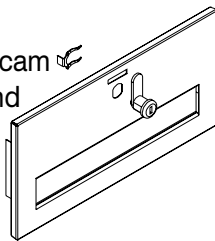

6. With the workbench upright, slide the drawer back into the drawer housing by tilting downward to let the drawer rollers move past each other.

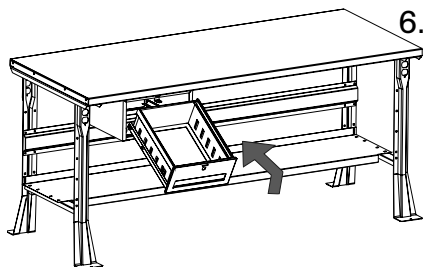

## Optional Lower Shelf

1. Place the shelf (Ref. No. 12) on the brace of each leg. Attach with three  $1/4$ "-20 x  $5/8$ " bolts and nuts on each end of the shelf as shown.

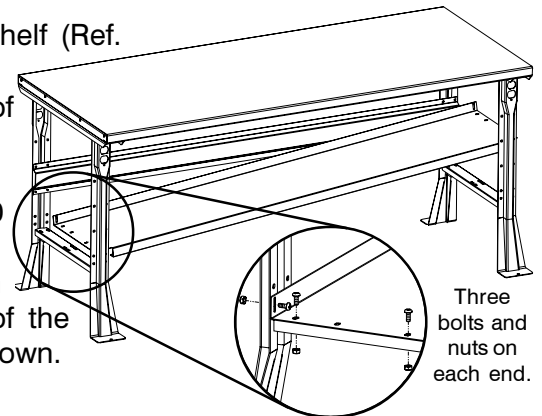

## Optional Riser or Electronic Riser

For assembly and installation of a riser or electronic riser, please refer to the instructions which came with the riser kit.

## Optional Side and Back Rails

1. If you are installing the optional side and back rails, and are also installing an optional riser, the riser must be in position first. **NOTE:** The riser and rails share some of the same bolts and nuts. To avoid having to re-do parts of the installation, please refer to the riser instructions as you install the side and back rails.

2. Place a side rail (Ref. No. 13) on one side of the workbench top, making sure that the rounded edge is toward the front of the bench. Attach with four  $1/4$ "-20 x  $5/8$  bolts and nuts along the bottom edge. Repeat this step for the other side of the workbench.

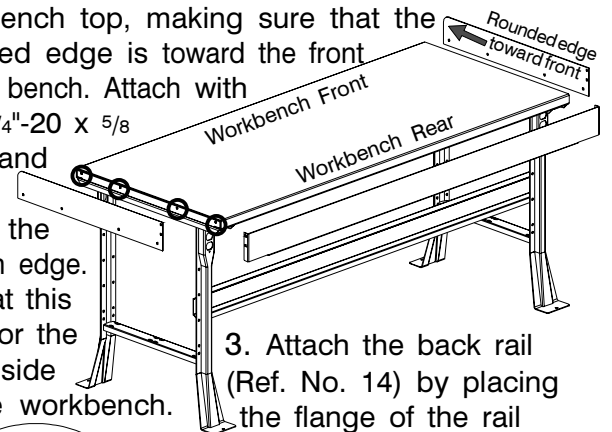

3. Attach the back rail (Ref. No. 14) by placing the flange of the rail under the bench top. Attach with eight  $1/4$ "-20 x  $5/8$ " bolts and nuts along the bottom. (**NOTE:** Where there is a mounting bracket under the bench, you will first need to remove the bolt from the mounting bracket. The bolt will go through both the back rail and the mounting bracket. No nut will be needed in these locations.)
4. Attach the back rail to the side rails, using two  $1/4$ "-20 x  $5/8$ " bolts and nuts on each end.

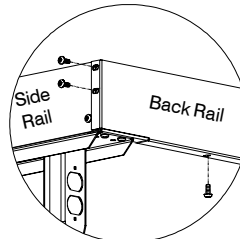

# REPLACEMENT PARTS

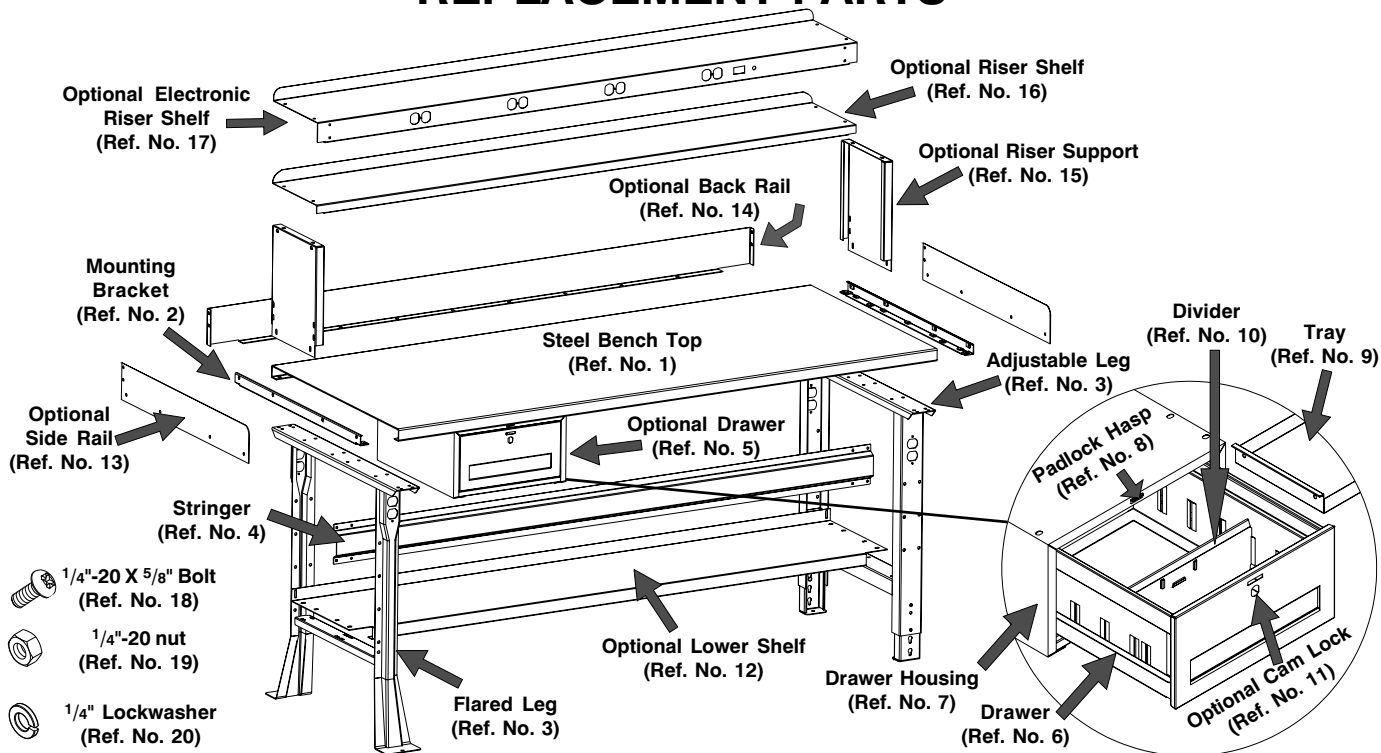

REF. NO.	DESCRIPTION	QTY.	PART NUMBER			
			60" w x 30" d	60" w x 36" d	72" w x 30" d	72" w x 36" d
1	Steel bench top with stringer	1	T-3060	T-3660	T-3072	T-3672
2	Mounting bracket	2 (pairs)	WBSR-30	WBSR-36	WBSR-30	WBSR-36
3	Flared workbench leg OR Adjustable workbench leg	1 (pair) 1 (pair)	L-3230 AL-3230	L-3236 AL-3236	L-3230 AL-3230	L-3236 AL-3236
4	Stringer (included with bench top)	1	WBS-60	WBS-60	WBS-72	WBS-72
5	Optional drawer (complete unit)	1	WBD-1	WBD-1	WBD-1	WBD-1
6	*Drawer	1	976CDW	976CDW	976CDW	976CDW
7	*Drawer housing	1	976CDH	976CDH	976CDH	976CDH
8	*Padlock hasp	1	976PH	976PH	976PH	976PH
9	*Tray	1	976T	976T	976T	976T
10	*Dividers	1	WBDD-12	WBDD-12	WBDD-12	WBDD-12
11	Optional cam lock	1	CL-1	CL-1	CL-1	CL-1
12	Optional lower steel shelf	1	S-60	S-60	S-72	S-72
13	Optional side rail	2	189SS	404SS	189SS	404SS
14	Optional back rail	1	189BS1	189BS1	404BS	404BS
15	Optional riser support	2	WBRS-2	WBRS-2	WBRS-2	WBRS-2
16	Optional riser shelf	1	WBRS-60	WBRS-60	WBRS-72	WBRS-72
17	Optional electronic riser shelf	1	EWRS-6015	EWRS-6015	EWRS-7215	EWRS-7215
18	1/4"-20 x 5/8" bolt	24		AVAILABLE LOCALLY		
19	1/4"-20 nut	12		AVAILABLE LOCALLY		
20	1/4" lockwasher	8		AVAILABLE LOCALLY		

\*Included in Ref. No. 5, optional drawer (WBD-1).

**We make every effort to ensure that all units ship complete with all parts and arrive undamaged. However, should your unit contain missing or damaged parts, replacements may be obtained directly from Tennsco. To obtain proper replacement parts, follow the instructions below:**

**TO OBTAIN PROPER REPLACEMENT PARTS, PLEASE PROVIDE THE FOLLOWING INFORMATION:**

- Model Number
- Description of part(s) needed and part number(s) as shown in Parts List (above)
- Color (i.e. Medium Grey, etc.)
- Purchase Date
- Your company name and contact person
- Who the product was purchased from
- Was item missing, or was it damaged?

**If requesting parts by telephone, please have as much of the above information ready as possible.**

This information may also be submitted online at [www.tennsco.com/replacement.cfm](http://www.tennsco.com/replacement.cfm)

**Tennsco Corp., P.O. Box 1888, Dickson, TN 37056-1888 Customer Service: (866) 446-8686 Fax: (800) 722-0134**