

Q LINE INDUSTRIAL SHELVING, OPEN STYLE Installation Instructions

Tennsco Corp., Dickson, TN 37056-1888 • (615) 446-8000

RETAIN INSTRUCTIONS FOR FUTURE REFERENCE!

Congratulations on your purchase of Q Line Industrial Shelving from **Tennsco**! Q Line shelving is designed for storage applications that demand strength and versatility. Available in a variety of heights, widths and depths, with either open or closed ends and backs, Q Line shelving is the answer for your heavy-duty storage needs.

Q Line's unique box-formation shelving structure provides added strength that makes it the strongest shelf in its class. The baked-on enamel finish assures years of trouble-free service, even under the most demanding situations. Compression clips provide boltless shelf attachment, making adding new shelves easy and convenient. Shelves can be adjusted quickly and easily in 1" increments, providing versatility.

Units can be used stand-alone, bolted side to side, or bolted back to back to suit your needs.

A wide variety of accessory items are available to suit your requirements, whether your needs are within the office or the factory.

GENERAL SAFETY INFORMATION

Some parts may have sharp edges. CARE must be taken when handling various pieces to avoid injury. For safety, wear a pair of work gloves when assembling or performing any maintenance on shelving.



ASSEMBLY OF Q LINE INDUSTRIAL SHELVING

Tools Needed: A 7/16" nut driver or socket and a flathead screwdriver. Label holder requires a Phillips screwdriver.
Requires one or two people for assembly. Approximate assembly time: 2 people, 15 to 30 minutes per station.

1. The reference numbers used throughout this sheet refer to the illustration on the back cover. This is to help you to identify the various parts as they are mentioned. **NOTE:** Number of shelves per unit varies depending on unit purchased.
2. Q Line uprights come in three different styles, as shown below:

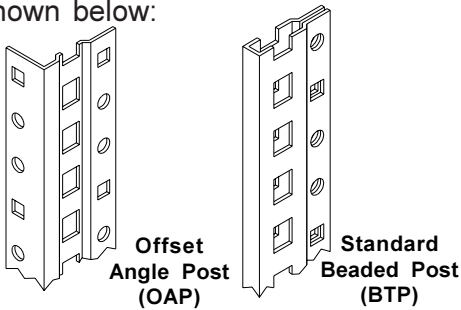

These three upright styles may be used in several different combinations. In order to better understand these instructions, please examine the following configurations to determine which type of installation you will be assembling:

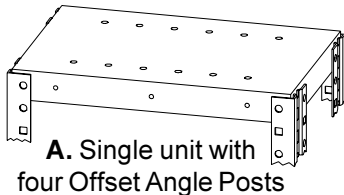

A. Single unit with four Offset Angle Posts

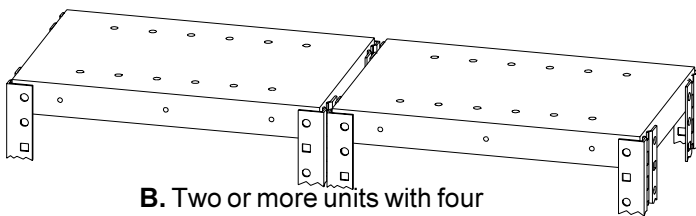

B. Two or more units with four Offset Angle Posts each

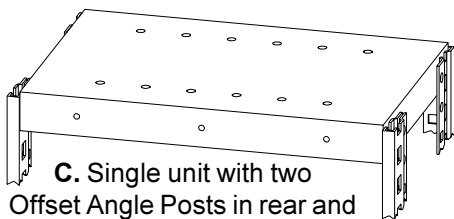

C. Single unit with two Offset Angle Posts in rear and two Standard or Heavy Beaded Posts in front.

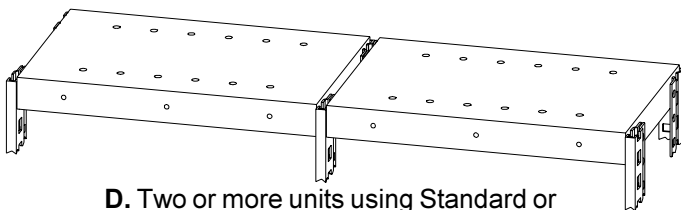

D. Two or more units using Standard or Heavy Beaded Posts in front.

3. Create the right side of the shelving units by laying two uprights side by side on a flat surface. Be sure that the short side of the OAP upright(s) (Ref. No. 1a) is facing up, as shown in Figure 3A.

IMPORTANT: One side of the upright is longer than the other, and contains two sets of holes. When laying the uprights side by side, this long side should be flat on the floor, and the short side should be pointing into the air.

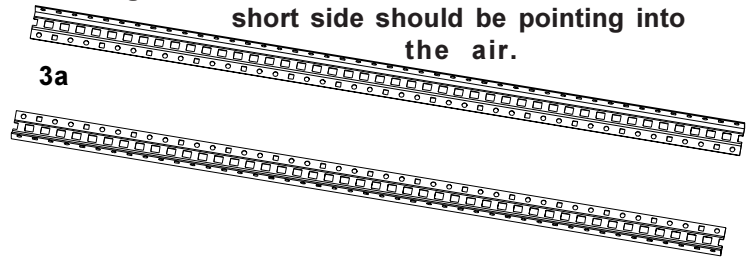

(If your unit will use BTP or HBP uprights in the front (Ref. Nos. 1b or 1c), be sure to select the proper upright and that the open edge is facing the OAP upright, as shown below in Figure 3B.)

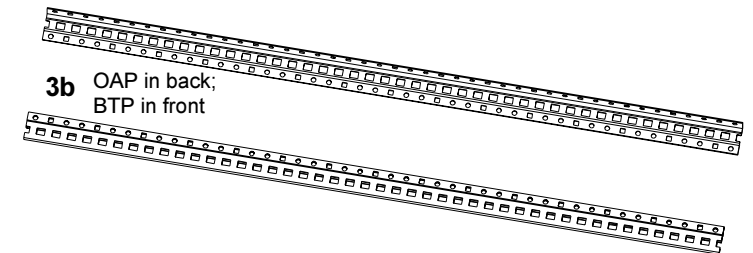

4. Attach the two side sway braces (Ref. Nos. 2a or 2b), beginning in the 20th hole from the top of each upright (approximately 20" from the top), using two 1/4"-20 x 5/8 bolts and nuts (Ref. No. 6). **The side sway braces attach to the longer side of the uprights (the side with two sets of holes).** Bolt the braces into the small holes near the edge of the uprights as shown in circles at below. Note the hole pattern of two round holes and then one square hole, repeating every 3", which should help facilitate proper placement of the bolts. Finger tighten only at this point.

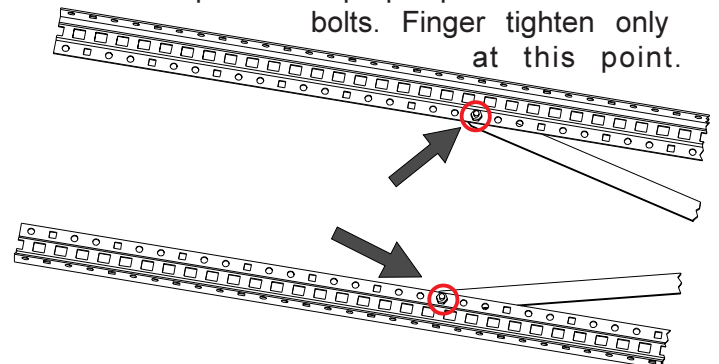

5. Attach the other end of both sway braces. The information below will help you to know how many holes should be between the top and bottom of the sway braces. Count the holes carefully, as an incorrect count will cause the upright to be the wrong depth to hold the shelves.

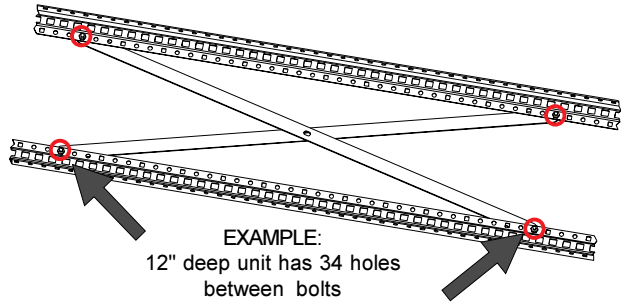

Unit Depth	Brace Length	Distance Between Bolts
12"	36 7/8"	36 holes (35")
15"	36 7/8"	35 holes (34")
18"	36 7/8"	34 holes (33")
24"	36 7/8"	30 holes (29")
30"	43 5/8"	34 holes (33")
36"	43 5/8"	28 holes (27")

6. Place one 1/4-20 x 5/8 bolt and nut in the hole where the two sway braces cross. Insert the bolt from the outside of the uprights, so that the nut will be inside the unit. Again, finger tighten only for the time being.

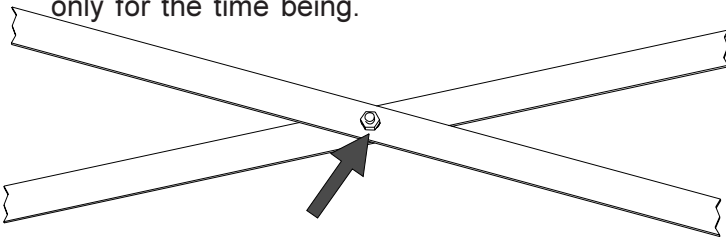

7. Repeat steps 3 through 6 for the left uprights. Again, be sure to note the type of uprights you should be using (according to the illustrations in step 2) for your type of installation. If you have purchased an adder unit such as the example in Figure 2D, please note that only ONE BTP or HBP is used in between the units.

You should now have complete left and right sides of your shelving unit, with sway brace bolts and nuts still finger-tightened only.

8. Have an associate hold one upright while you place four shelf clips (Ref. No. 3) in the top and bottom holes of each post, as shown below.

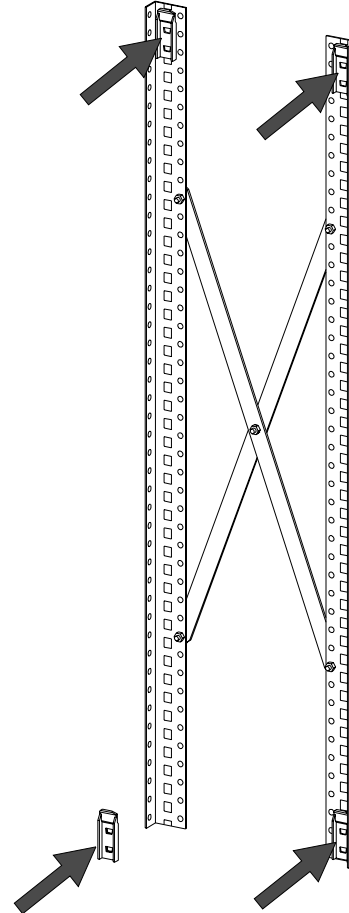

9. Place a shelf (Ref. No. 4a or 4b) onto the bottom two clips.

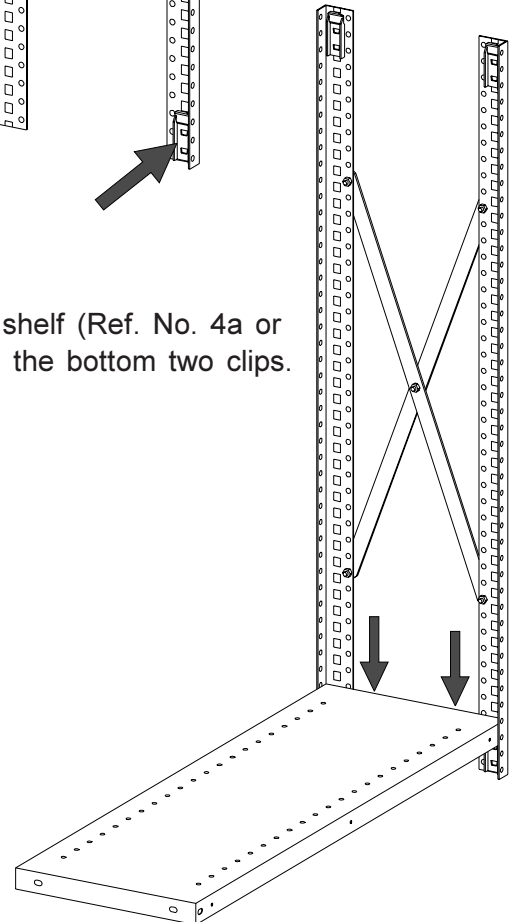

10. Tie in the two sets of uprights with the bottom shelf.

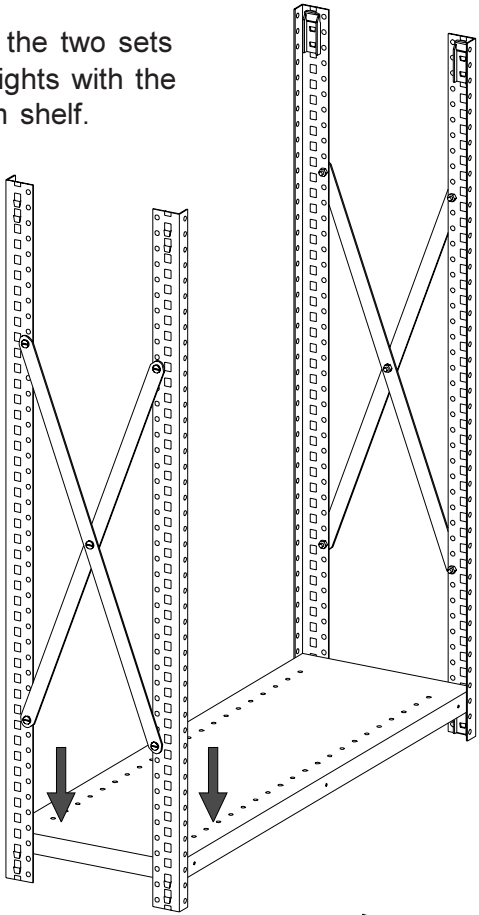

11. Place the top shelf over the four clips at the top of the upright.

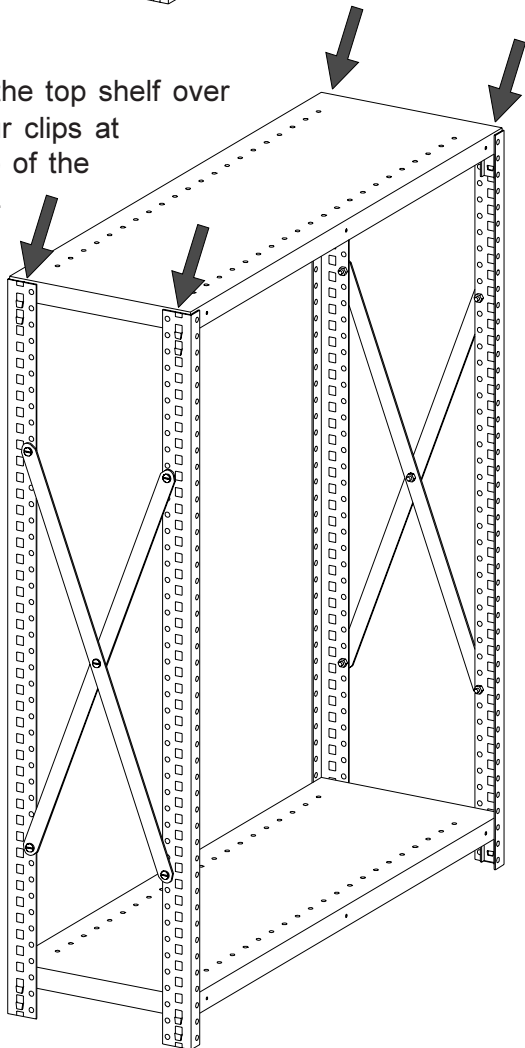

12. Bolt the rear sway braces (Ref. No. 5) on the back of the unit, using five 1/4-20 x 5/8 bolts and nuts, as shown. Again, the top of the sway braces should be in the 20th hole from the top of each upright (approximately 20 inches from the top). The chart below will help you determine the proper number of holes between the top and bottom of the sway braces. Note that the hole count **INCLUDES** the holes which will contain the bolts.

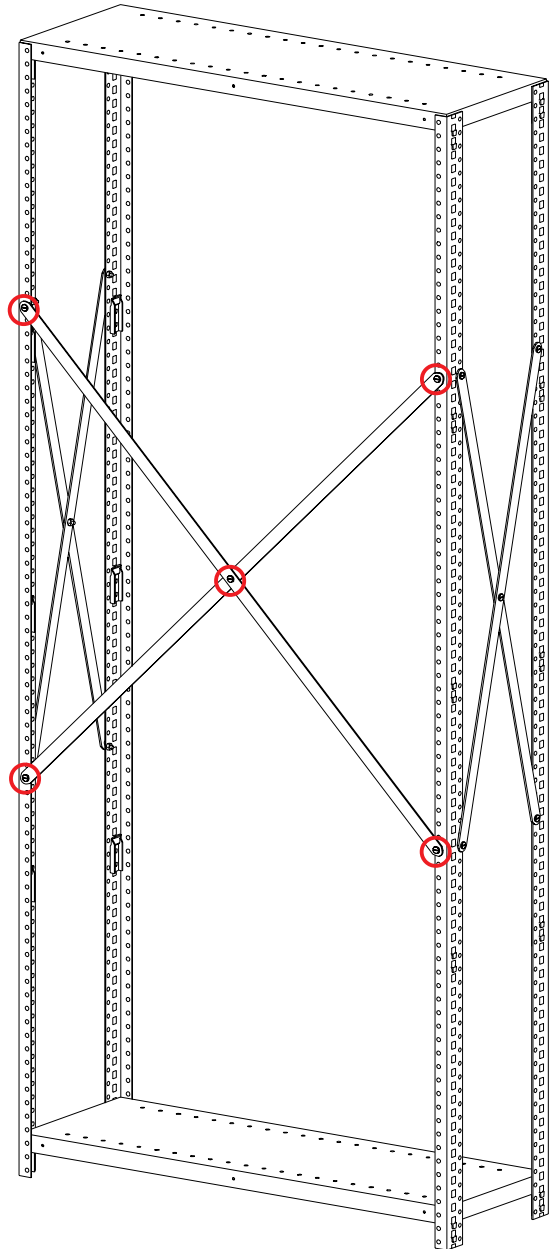

Unit Width	Brace Length	Distance Between Bolts
36"	56 11/32"	44 holes (43")
42"	56 11/32"	38 holes (37")
48"	56 11/32"	30 holes (29")

13. Position the remaining shelf clips according to your desired shelf heights, and place the shelves over the clips. Keep in mind, while placing the clips, that the hole pattern of two round holes and then one square hole, repeated every 3", can greatly help in aligning the clips evenly.

PLEASE NOTE: Some shelves, depending upon placement, could possibly require temporarily removal of one end of a sway brace in order to insert the shelf.

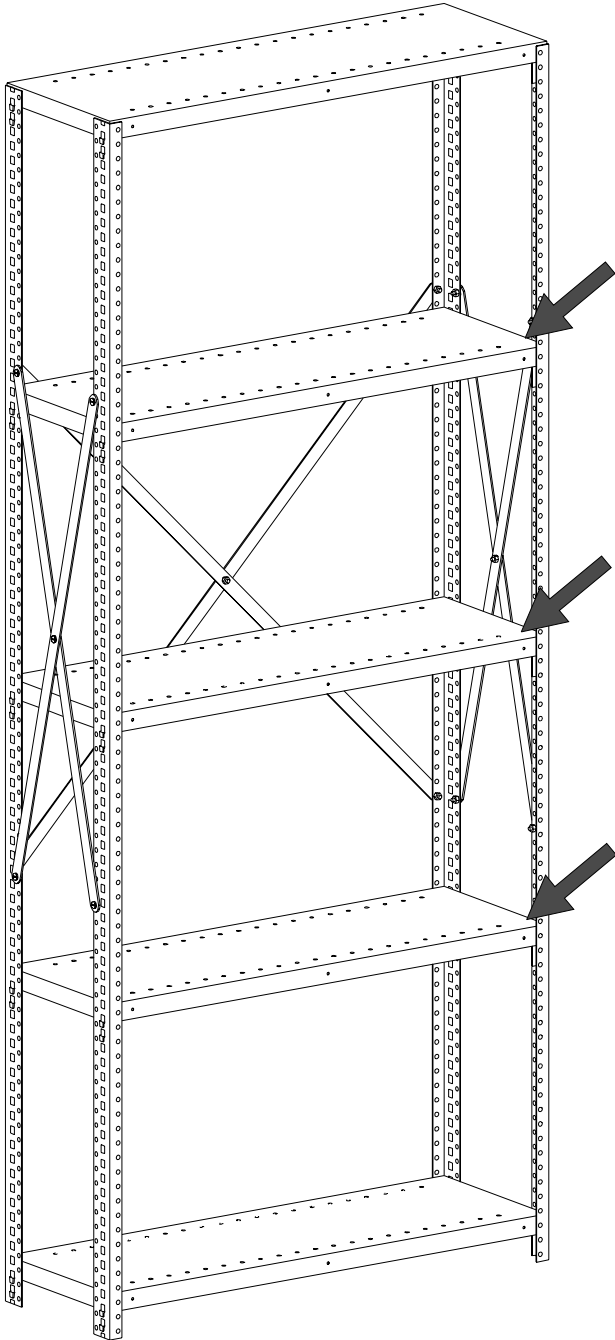

14. Tighten up all bolts and nuts on the rear and side sway braces. There are fifteen bolts and nuts to tighten, five for each pair of sway braces.

15. **OPTIONAL Label Holder:** Place the label holder (Ref. No. 7) on the front edge of the shelf and secure with three P-38F plastic tabs.

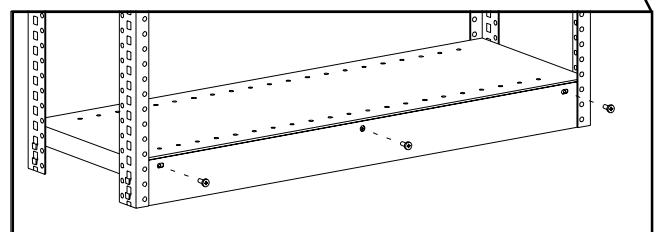
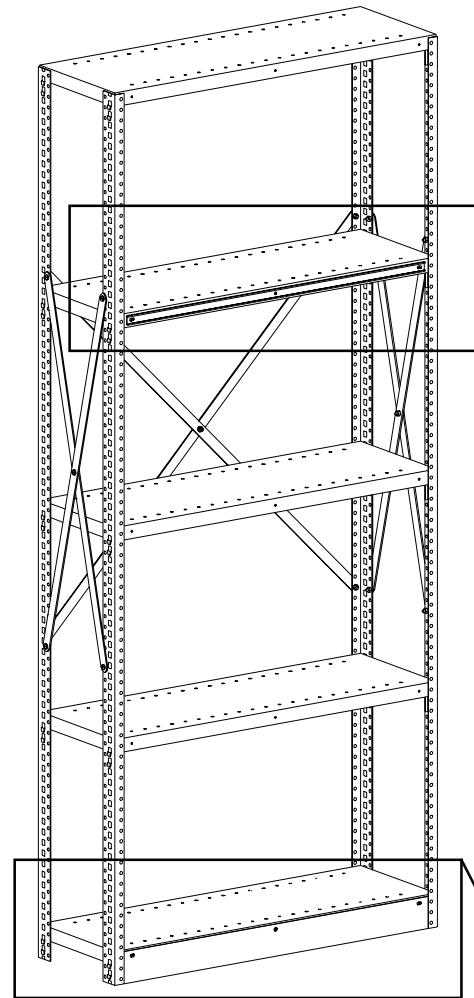
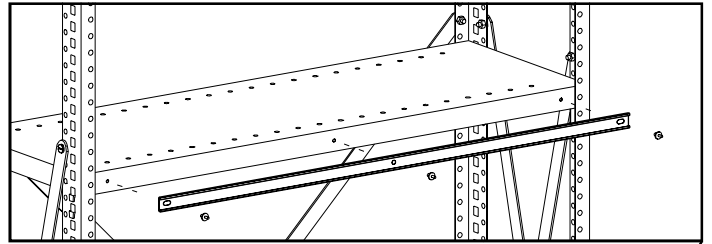

16. **OPTIONAL Front Base Strip:** Bolt front base strip (Ref. No. 8) to the outside of the bottom shelf with the three self-tapping screws provided. Make sure that the ends of the front base strip are behind the front flanges of the uprights.

17. For even better reinforcement, place two $1/4$ -20 x $5/8$ " bolts and nuts (available locally) through each corner of each shelf, and into the small holes of the upright.

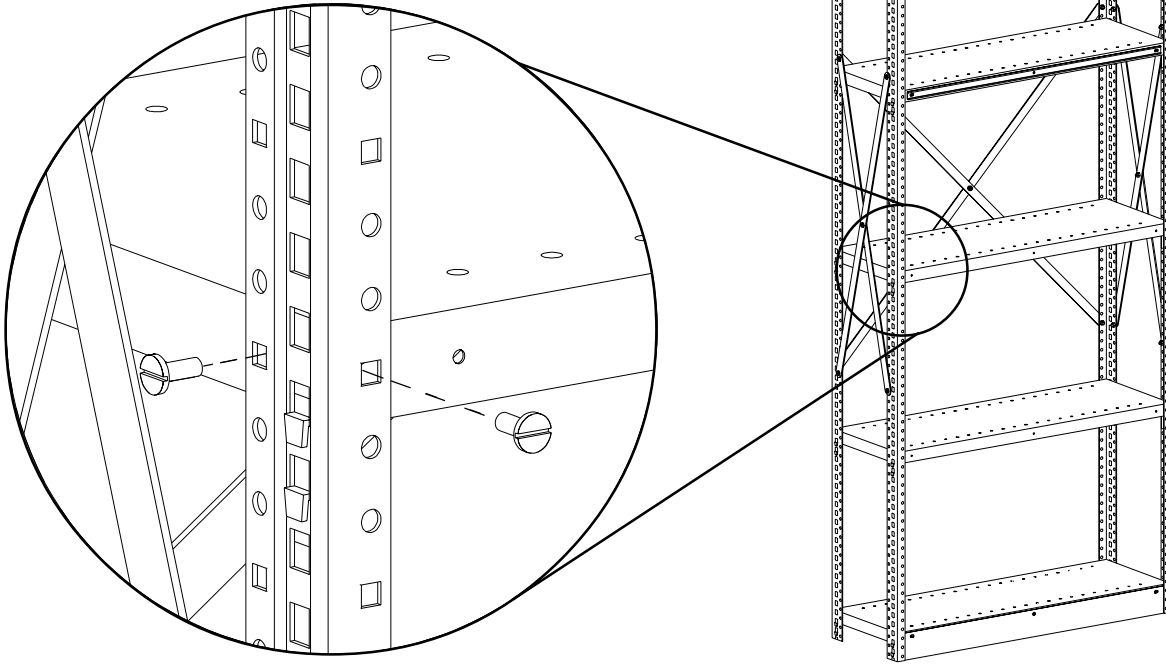

18. If more than one unit is to be used in a row, bolt a pair of upright posts to the first unit with $1/4$ -20 x 1" bolts and nuts. (Note that where BTP or HBP posts are used, two units will share one post.) The pair of side braces on the first unit becomes a common pair for the two units.

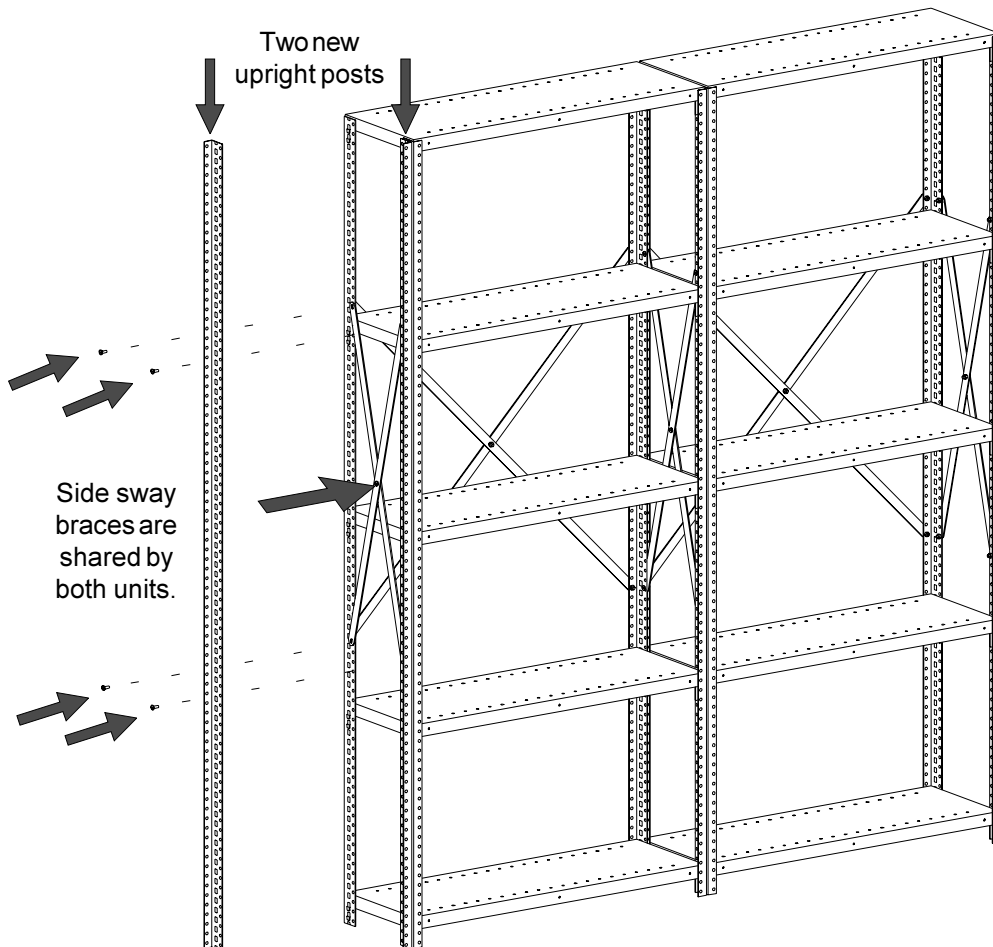

19. If two units are to be used back-to-back, the back braces on the first unit become a common pair for the two units.

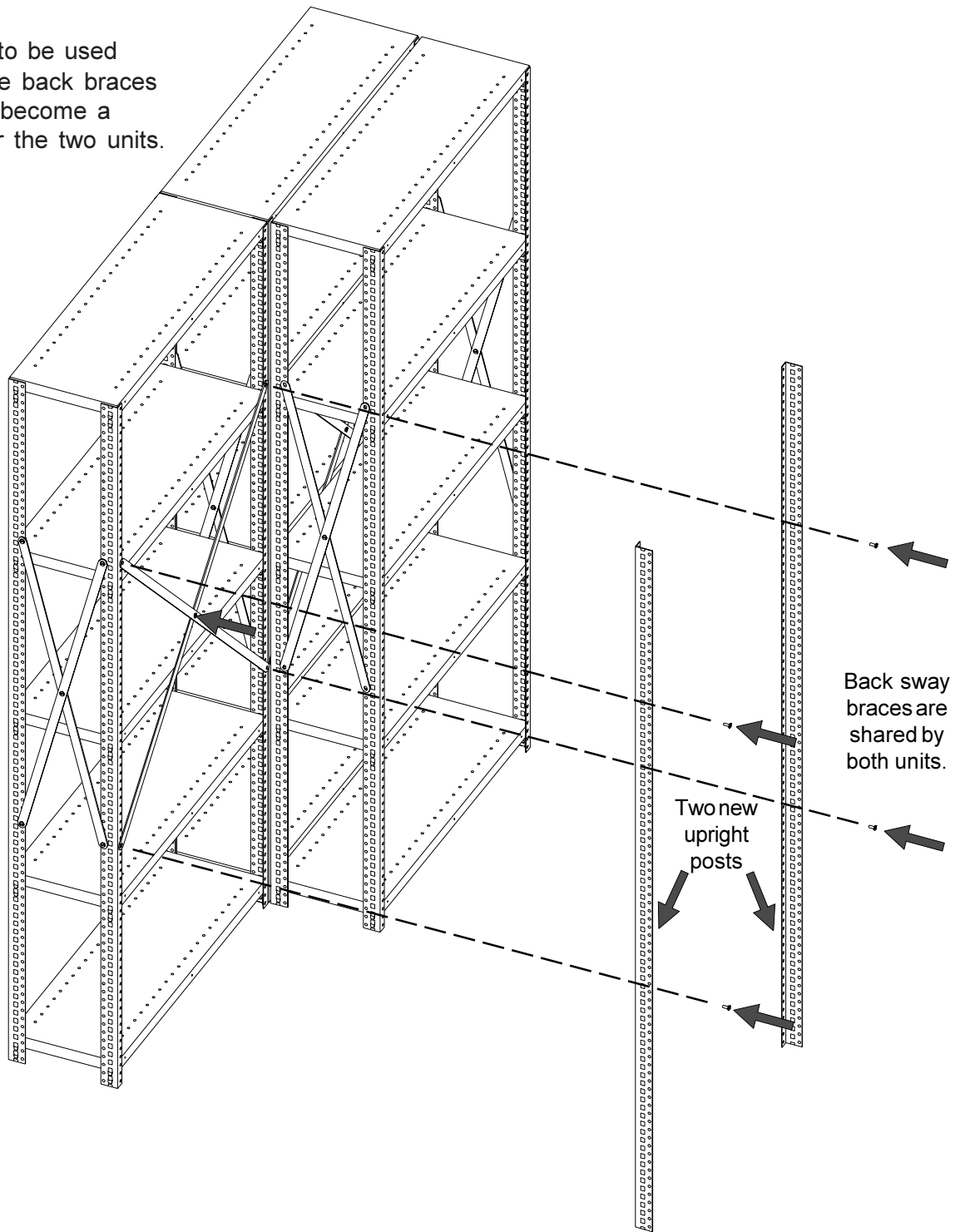

LIMITED WARRANTY

Tennsco warrants goods purchased hereunder to be free of defects in materials and workmanship for a period of one (1) year from the date of shipment, hereunder. This warranty shall not apply in the event goods are damaged as a result of misuse, abuse, neglect, accident, improper application, modification or repair by persons not authorized by Seller, where goods are damaged during shipment, or where the date stamps on the goods have been defaced, modified or removed. UNLESS CONSIDERED UNENFORCEABLE OR UNLAWFUL UNDER APPLICABLE LAW:

- a. ALL IMPLIED WARRANTIES, INCLUDING BUT NOT LIMITED TO WARRANTIES OR MERCHANTABILITY AND FITNESS FOR A PARTICULAR PURPOSE ARE HEREBY EXCLUDED:
- b. BUYERS REMEDY, IF ANY, FOR ANY DEFECTIVE GOODS SHALL BE LIMITED TO A REFUND BY SELLER OR REPLACEMENT OF THE GOODS AT SELLER'S OPTION, AND SHALL IN NO EVENT INCLUDE DAMAGES OF ANY KIND, WHETHER INCIDENTAL, CONSEQUENTIAL OR OTHERWISE.

NO GOODS ACCEPTED FOR RETURN WITHOUT PRIOR APPROVAL. Seller shall have the right to inspect any goods claimed to be defective at Buyers place of business or require Buyer to return the goods to Seller for inspection on Seller's premises. Transportation charges covering returned goods will be borne by Seller only if such goods are proven to be defective, are covered by this warranty and are returned within the warranty period stated above.

TENNSCO CORP., P.O. BOX 1888, DICKSON, TN 37056-1888
(615) 446-8000 (800) 251-8184

REPLACEMENT PARTS

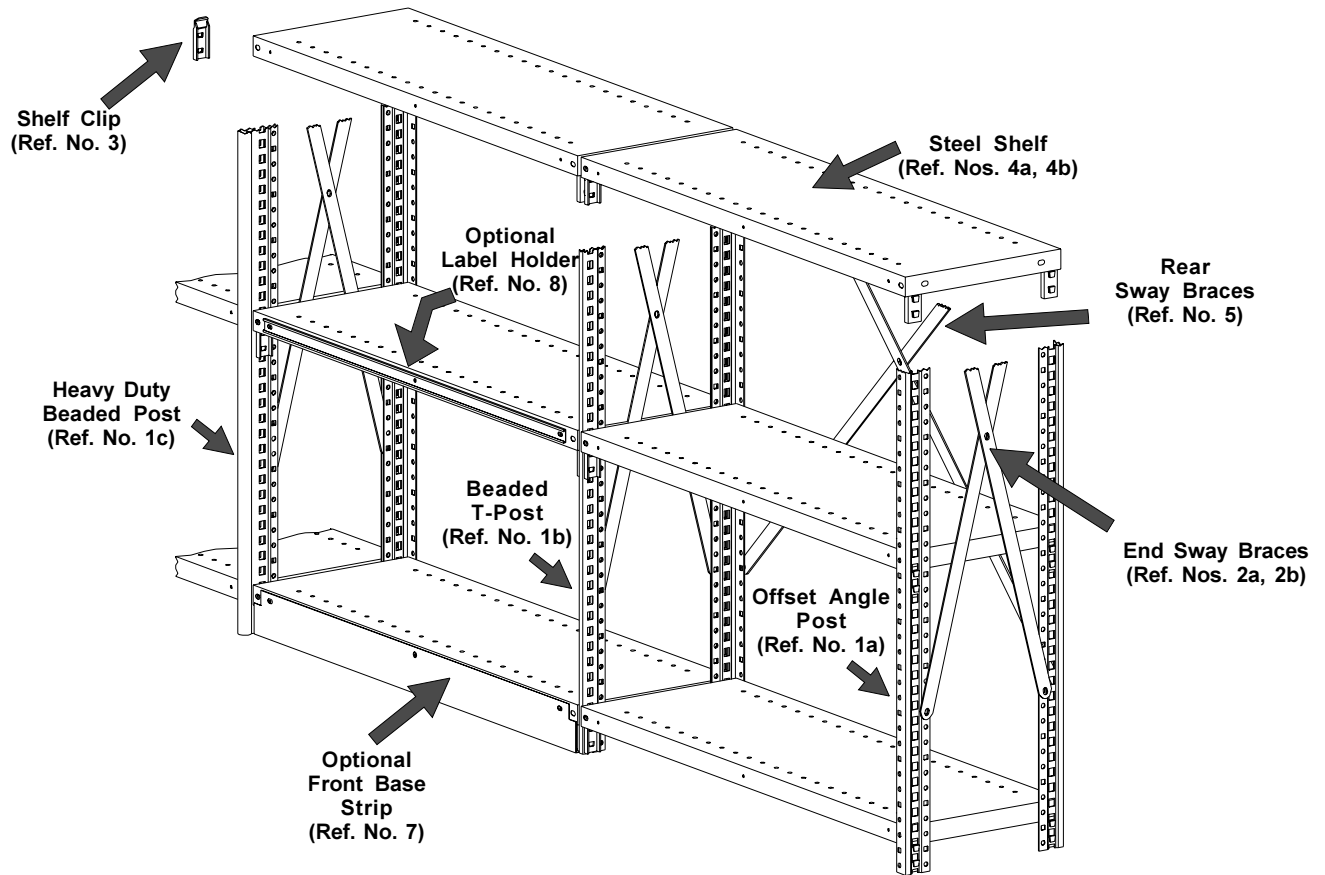

BASIC UNIT PARTS			OPTIONAL ITEMS		
REF. NO.	DESCRIPTION	PART NO.	REF. NO.	DESCRIPTION	PART NO.
1a	Offset Angle Post	OAP-hh	7	Optional Front Base Strip	FBS-ww2
1b	Beaded T-Post	BTP-hh	8	Optional Label Holder	LH-ww
1c	Heavy Duty Beaded Post	HBP-hh	—	Optional Hinged Door & Frame	HD-3687
2a	End Sway Braces (Pair), 12" to 24"	ESB-1224	—	Optional Bin Dividers	BD-ddhh
2b	End Sway Braces (Pair), 30" to 36"	ESB-3036	—	Optional Bin Front	BF-wwh
3	Shelf Clip	T-1	—	Optional End Panel	EP-ddhh
4a	22 gauge steel shelf	Q2-wwdd	—	Optional Back Panel	BP-wwhh
4b	20 gauge steel shelf	Q-wwdd	—	Optional Foot Plate	FP-1
5	Rear Sway Braces (Pair), 48"	RSB-48	—	Optional Sliding Divider	SD-ddhh
6	1/4-20 x 5/8" bolts and nuts	—	—	Optional Shelf Box	BX-wwdd

*Where the suffix "ww", "dd", or "hh" is used in the part number, the width (ww), depth (dd) or height (hh) is substituted in the part number. For example, for an 84" high Offset Angle Post, the part number would be OAP-84.

Tennsco makes every effort to ensure that all units ship complete with all parts and arrive undamaged. However, should your unit contain missing or damaged parts, replacements may be obtained directly from Tennsco. To obtain proper replacement parts, follow the instructions below:

TO OBTAIN PROPER REPLACEMENT PARTS, PLEASE PROVIDE THE FOLLOWING INFORMATION:

- Model Number
- Description of part(s) needed and part number(s) as shown in Parts List (above)
- Color (i.e. Medium Grey, etc.)
- Was item missing, or was it damaged?
- Purchase Date
- Your company name
- Contact person's name
- Who the product was purchased from

Tennsco Corp., P.O. Box 1888, Dickson, TN 37056-1888 Voice: (800) 251-8184 Fax: (800) 722-0134
 If requesting parts by telephone, ask for customer service and have as much of the above information as possible.