



TENNSCO STORAGE CABINET

Model 1470

Tennsco Corp., Dickson, TN 37056-1888 • (615) 446-8000

RETAIN INSTRUCTIONS FOR FUTURE REFERENCE!

Congratulations on your purchase of a Tennsco Storage Cabinet! Tennsco's 1470 units are general purpose storage cabinets that provide a level of quality you won't find elsewhere. They provide secure storage for office supplies, books, records, small parts, tools, etc.

These cabinets offer five openings with four adjustable shelves, a locking chrome handle with two keys, and a three-point locking system for extra security.

Tennsco's cabinets are constructed from top quality 22 or 24 gauge steel, with 22 gauge steel shelves offering weight capacities of up to 200 lbs. per shelf (evenly distributed). Our attractive and durable powder-coated paint finish will provide for years of service.

GENERAL SAFETY INFORMATION

Some parts may have sharp edges. CARE must be taken when handling various pieces to avoid injury. For safety, wear a pair of work gloves when assembling or performing any maintenance on your cabinet.



LIMITED WARRANTY

Tennsco warrants goods purchased hereunder to be free of defects in materials and workmanship for a period of one (1) year from the date of shipment, hereunder. This warranty shall not apply in the event goods are damaged as a result of misuse, abuse, neglect, accident, improper application, modification or repair by persons not authorized by Seller, where goods are damaged during shipment, or where the date stamps on the goods have been defaced, modified or removed. UNLESS CONSIDERED UNENFORCEABLE OR UNLAWFUL UNDER APPLICABLE LAW:

- a. ALL IMPLIED WARRANTIES, INCLUDING BUT NOT LIMITED TO WARRANTIES OR MERCHANTABILITY AND FITNESS FOR A PARTICULAR PURPOSE ARE HEREBY EXCLUDED:
- b. BUYERS REMEDY, IF ANY, FOR ANY DEFECTIVE GOODS SHALL BE LIMITED TO A REFUND BY SELLER OR REPLACEMENT OF THE GOODS AT SELLER'S OPTION, AND SHALL IN NO EVENT INCLUDE DAMAGES OF ANY KIND, WHETHER INCIDENTAL, CONSEQUENTIAL OR OTHERWISE.

NO GOODS ACCEPTED FOR RETURN WITHOUT PRIOR APPROVAL. Seller shall have the right to inspect any goods claimed to be defective at Buyers place of business or require Buyer to return the goods to Seller for inspection on Seller's premises. Transportation charges covering returned goods will be borne by Seller only if such goods are proven to be defective, are covered by this warranty and are returned within the warranty period stated above.

TENNSCO Corp., P.O. BOX 1888, DICKSON, TN 37056-1888
(615) 446-8000 or (866) 446-8686 (toll free)
Website: www.tennsco.com E-mail: Info@tennsco.com

INSTALLATION OF 1470 CABINETS

Tools Needed: A free $1\frac{1}{32}$ " nut driver is provided with each Tensco cabinet (Ref. No. 17). In addition, you will need a flathead screwdriver. A hammer is required to install the hinge pin and lock bar.

Two people recommended for installation. Approximate assembly time: 15 to 25 minutes.

1. The reference numbers used throughout this sheet refer to the illustration on the back cover. This is to help you to identify the various parts as they are mentioned.

2. Place the cabinet back (Ref. No. 1) on a protected surface to prevent scratching the paint. The flange on the bottom of the back should be facing upward.

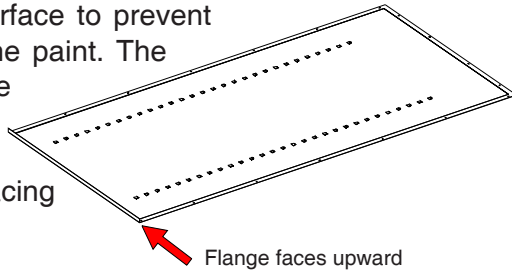

3. Attach the left side (Ref. No. 2) to the back by placing flange (A) around the back and bolting the back and side together with seven bolts and nuts (Ref. Nos. 18 & 19). Be sure that the lances on all shelf adjustment strips (B) point in the same direction.

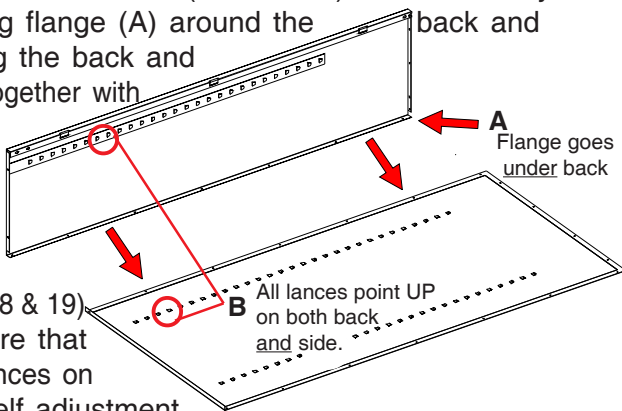

4. Attach the right side (Ref. No. 3) to the back in the same manner as you did in step 3, again making sure that the flange is around the back and that the lances on the shelf adjustment strips are pointed in the same direction as those on the back and left side.

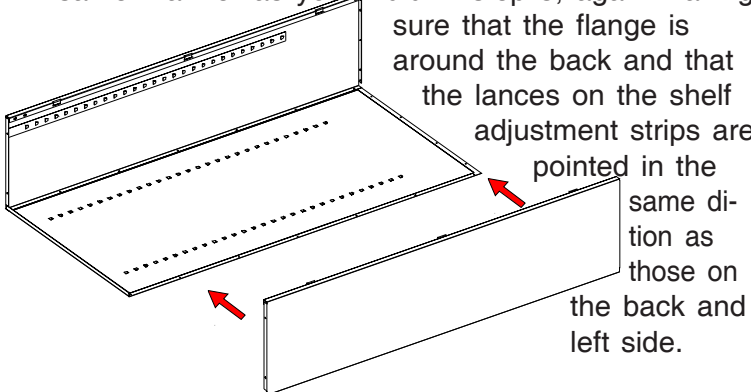

5. To help hold the sides in position, insert one shelf (Ref. No. 4) into the approximate center of the unit, inserting the shelf edges into the lances on all four shelf adjustment strips. Be sure that the channeled edge of the shelf is toward the cabinet front. If a lance is too tight, it may be helpful to use a screwdriver to SLIGHTLY pry it open.

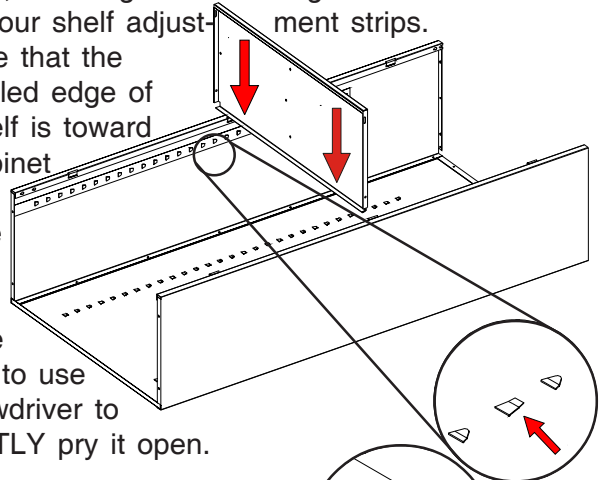

6. Insert bolts into the outside holes on the header (Ref. No. 5), placing two on each end as shown in Inset A. Attach the nuts, but do not tighten. Next, insert the loose bolt heads on the header into the large keyhole slots at the top of each side panel. Slide the bolt heads securely into the smaller end of the keyhole slot, and tighten the four nuts securely.

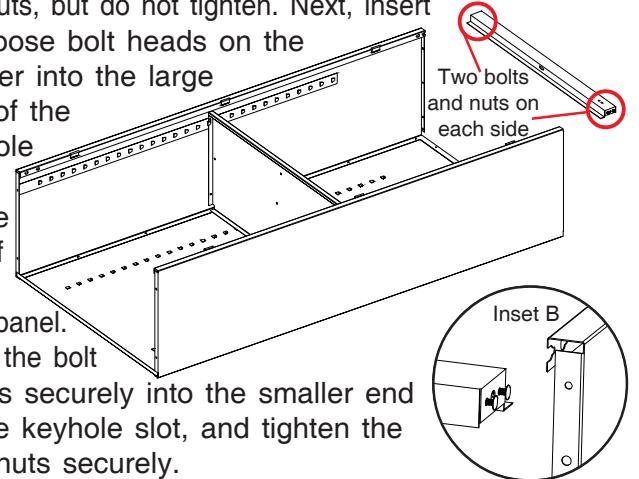

7. Attach the sill (Ref. No. 6) to the two holes on each side of the cabinet bottom, using the same technique you used to attach the header in step 6.

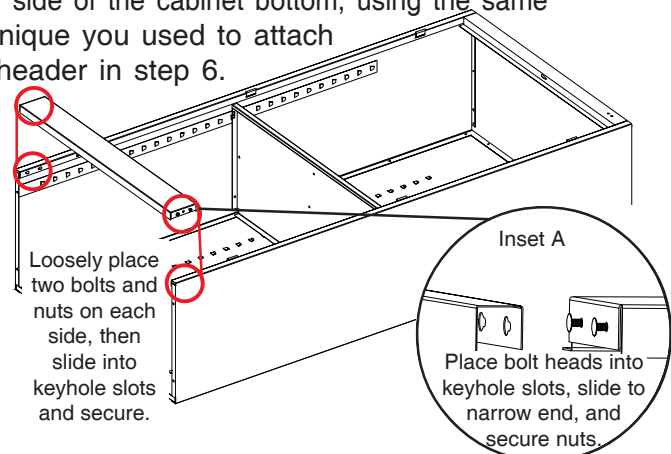

8. Place bottom (Ref. No. 7) in the bottom lances of the shelf adjustment strips.

The flange with two holes should face the front, and it should hang over the sill.

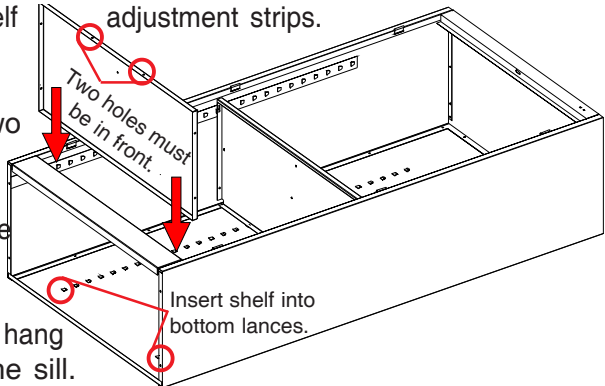

Bolt to the sill with two bolts and nuts.

9. Attach the top (Ref. No. 8) by sliding it under the header and sides, with the flange hanging over the back.

Secure with 14 bolts & nuts (three along each side, four in the back, and four along the front).

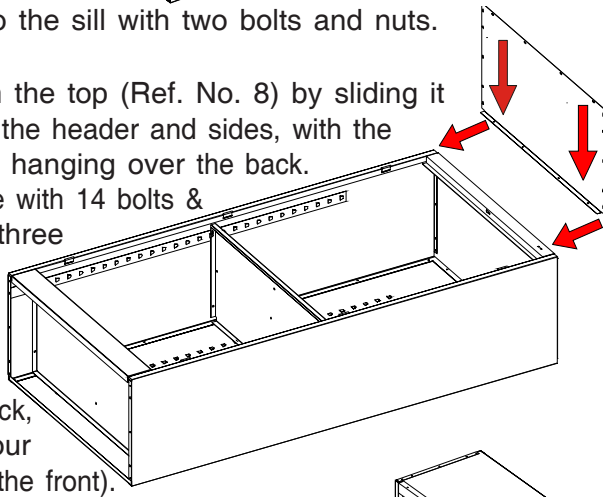

10. Set the unit upright and insert the remaining shelves at your desired levels.

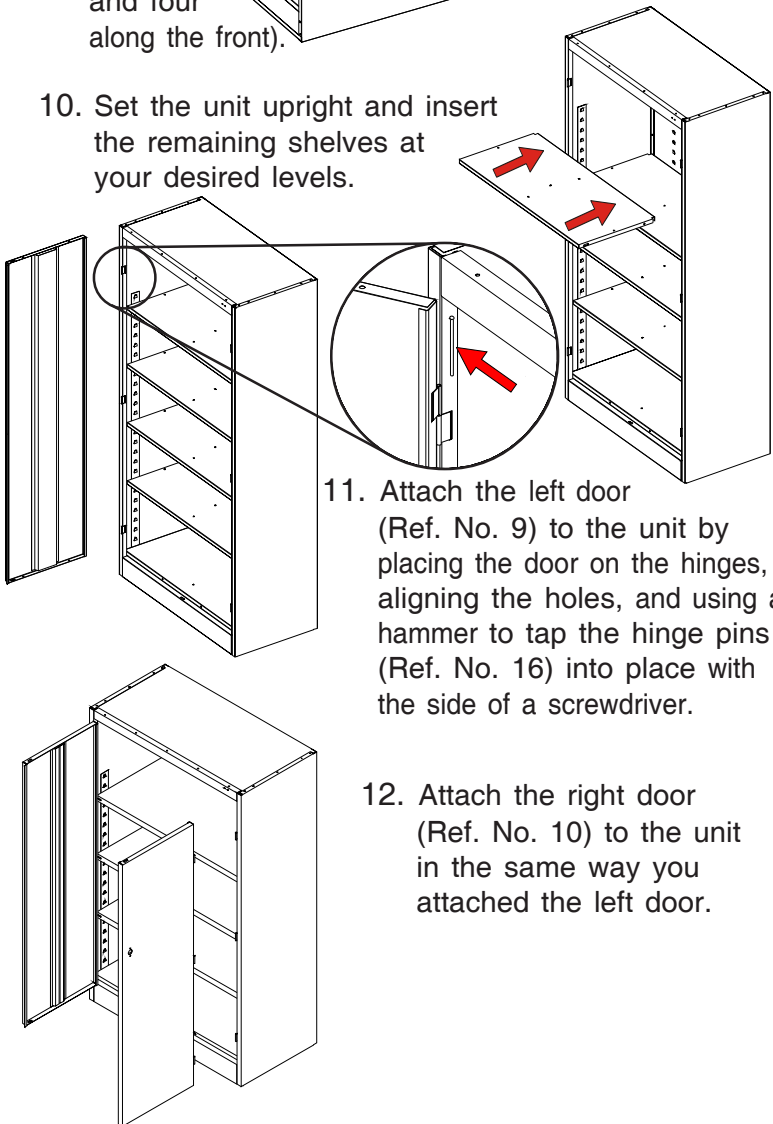

11. Attach the left door (Ref. No. 9) to the unit by placing the door on the hinges, aligning the holes, and using a hammer to tap the hinge pins (Ref. No. 16) into place with the side of a screwdriver.

12. Attach the right door (Ref. No. 10) to the unit in the same way you attached the left door.

Handle/Locking System Installation Instructions

1. Place the locking handle (Ref. No. 12) on the right hand door and fasten with two #8-32 x 1/4" slotted hex-head bolts and lockwashers (Ref. No. 17).

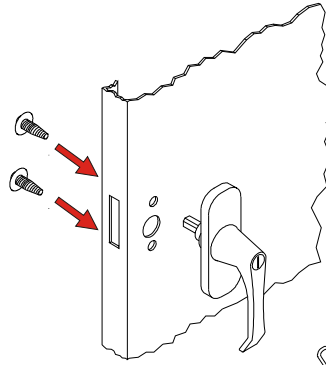

2. Turn the handle to the open position, and place the locking cam (Ref. No. 13) over the square shank of the door handle. The latch must be facing downward as shown. Then place the locking cotter pin (Ref. No. 14) through the hole of the square shank, as shown at right.

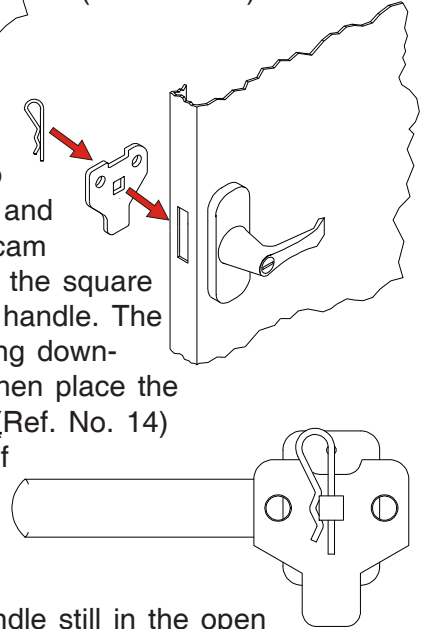

3. With the handle still in the open position, hook the locking bars (Ref. No. 11) to the locking cam (see "A" at left). Once in position, slowly rotate the door handle to the closed position so the lock bars protrude from the holes at the top and bottom of the door (shown at right, below).

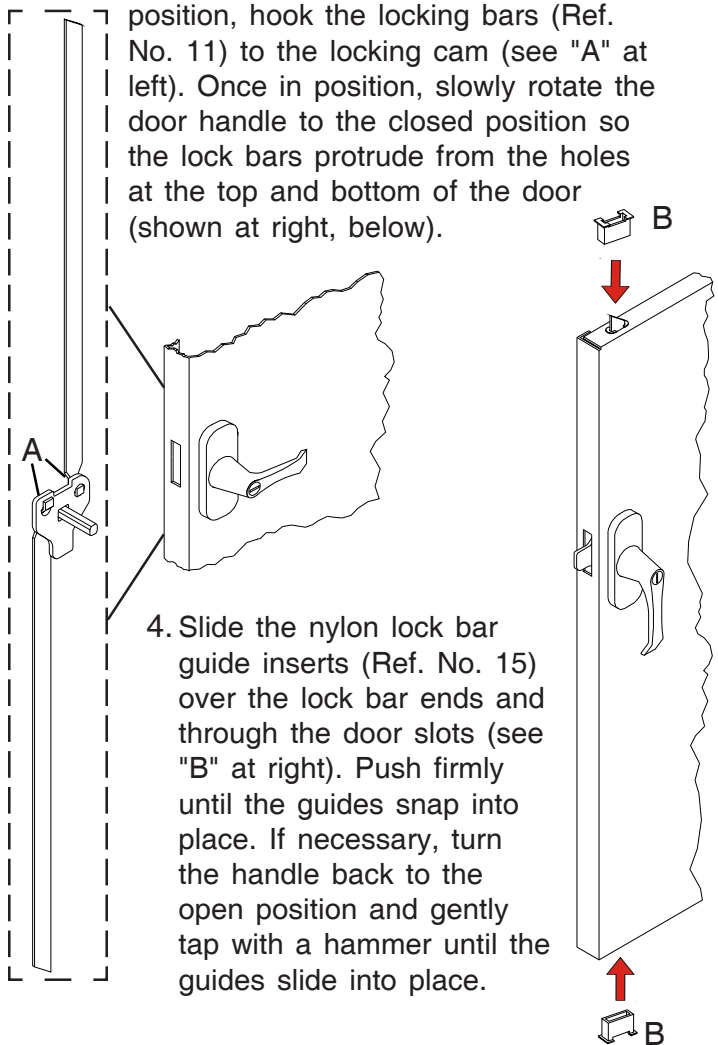

4. Slide the nylon lock bar guide inserts (Ref. No. 15) over the lock bar ends and through the door slots (see "B" at right). Push firmly until the guides snap into place. If necessary, turn the handle back to the open position and gently tap with a hammer until the guides slide into place.

REPLACEMENT PARTS

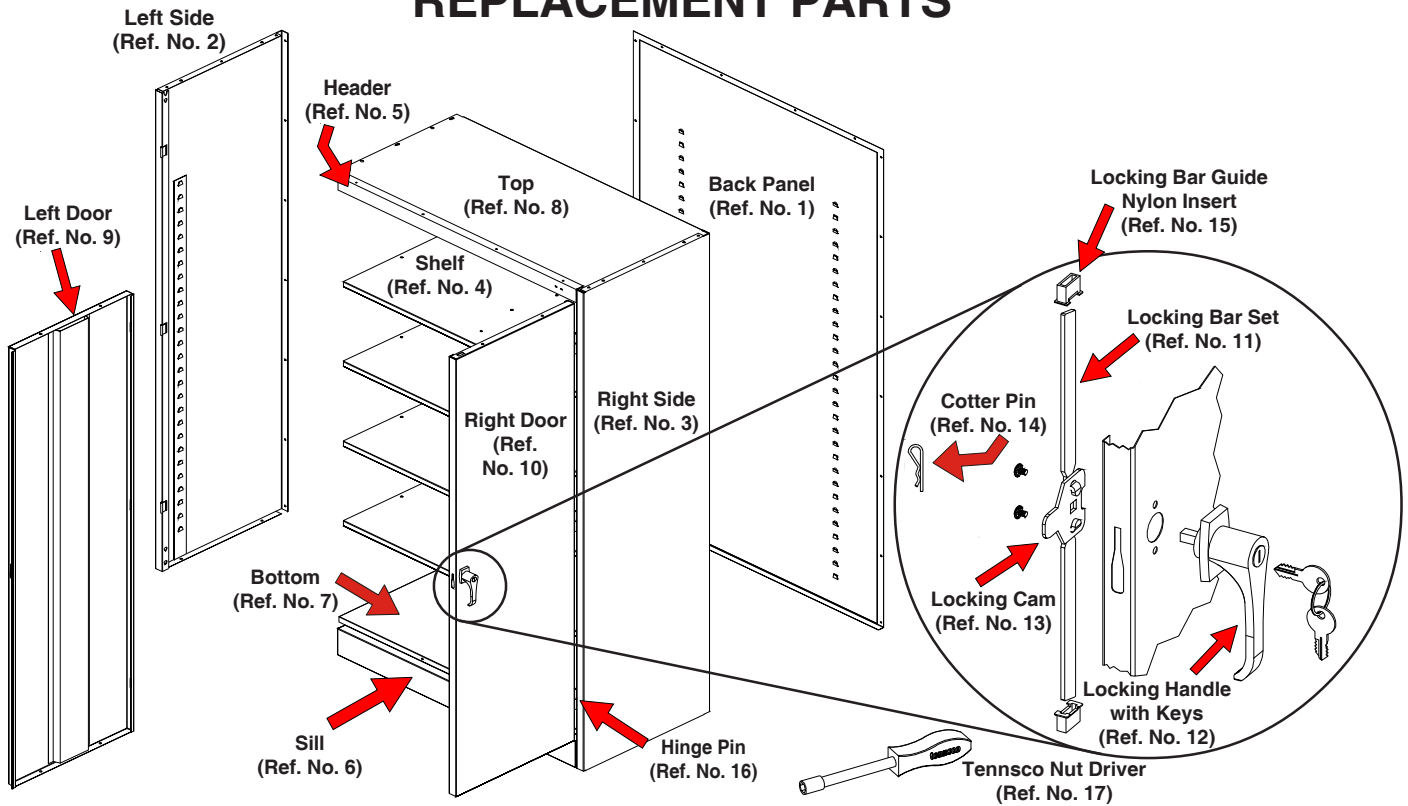

| REF. NO. | DESCRIPTION | QTY. | PART NO. |
|----------|-----------------------------------|------|-------------------|
| 1 | Back panel | 1 | 944BA |
| 2 | Left side | 1 | 944LS |
| 3 | Right side | 1 | 944RS |
| 4 | Shelf | 4 | 301 |
| 5 | Header | 1 | 944HE |
| 6 | Sill | 1 | 944SI |
| 7 | Bottom | 1 | 944BO |
| 8 | Top | 1 | 944TO |
| 9 | Left door | 1 | 944LD |
| 10 | Right door | 1 | 944RD |
| 11 | Locking bar set | 1 | 944LB |
| 12 | Locking handle w/keys & hardware | 1 | 944LH |
| 13 | Locking cam* | 1 | 944LC |
| 14 | Cotter pin* | 1 | CTRPN |
| 15 | Locking bar guide insert (nylon)* | 2 | 944GI |
| 16 | Hinge pin | 6 | 944HP |
| 17 | Tennsco nut driver | 1 | TOOL-2 |
| 18 | #8-32 x 3/8"bolts* | 44 | AVAILABLE LOCALLY |
| 19 | #8-32 nuts* | 44 | AVAILABLE LOCALLY |

*Included in Ref. No. 12, locking handle with keys and hardware (Part No. 944LH).

Tennsco makes every effort to ensure that all units ship complete with all parts and arrive undamaged. However, should your unit contain missing or damaged parts, replacements may be obtained directly from Tennsco. To obtain proper replacement parts, follow the instructions below: (or fill out the form at www.tennsco.com/replacement.cfm)

TO OBTAIN PROPER REPLACEMENT PARTS, PLEASE PROVIDE THE FOLLOWING INFORMATION:

- Model Number (1470)
- Description of part(s) needed and part number(s) as shown in Parts List (above)
- Color (i.e. Medium Grey, etc.)
- Was item missing, or was it damaged?
- Purchase Date
- Your company name
- Contact person's name
- Who the product was purchased from

Tennsco Corp., P.O. Box 1888, Dickson, TN 37056-1888 Customer Service: (866) 446-8686 Fax: (866) 445-7260
If requesting parts by telephone, ask for customer service and have as much of the above information ready as possible.