

ASSEMBLY INSTRUCTIONS

Sort and count your parts!

PARTS LIST			
LETTER CODE	DESCRIPTION	QTY.	PART NO.
(A)	Lower Post	1	8921-04
(B)	Base	1	8921-05
(C)	Bolt (fully threaded)	1	8921-27
(D)	Upper Post	1	8921-03
(E)	Knob, Long Stem	2	8921-25
(F)	Adjustment Bracket	1	8921-02
(G)	Retaining Bracket	1	8921-09
(H)	Top Platform	1	8921-01
(I)	Small Screw	6	8921-22
(J)	Paper Stop/Pencil Ledge	1	8921-08
(K)	Pivot Bolt	1	8921-23
(L)	Nut	1	8921-24
(M)	Star Washer	1	8921-21
(N)	Knob, Short Stem	1	8921-26

TOOLS REQUIRED: Phillips Screwdriver, Flat Screwdriver
When ordering replacement parts, please specify color.

For questions or concerns, please call
Safco Consumer Hot Line 1-800-664-0042
available Monday-Friday 8:00 AM to 4:30 PM (Central Time)
(English-speaking operators)

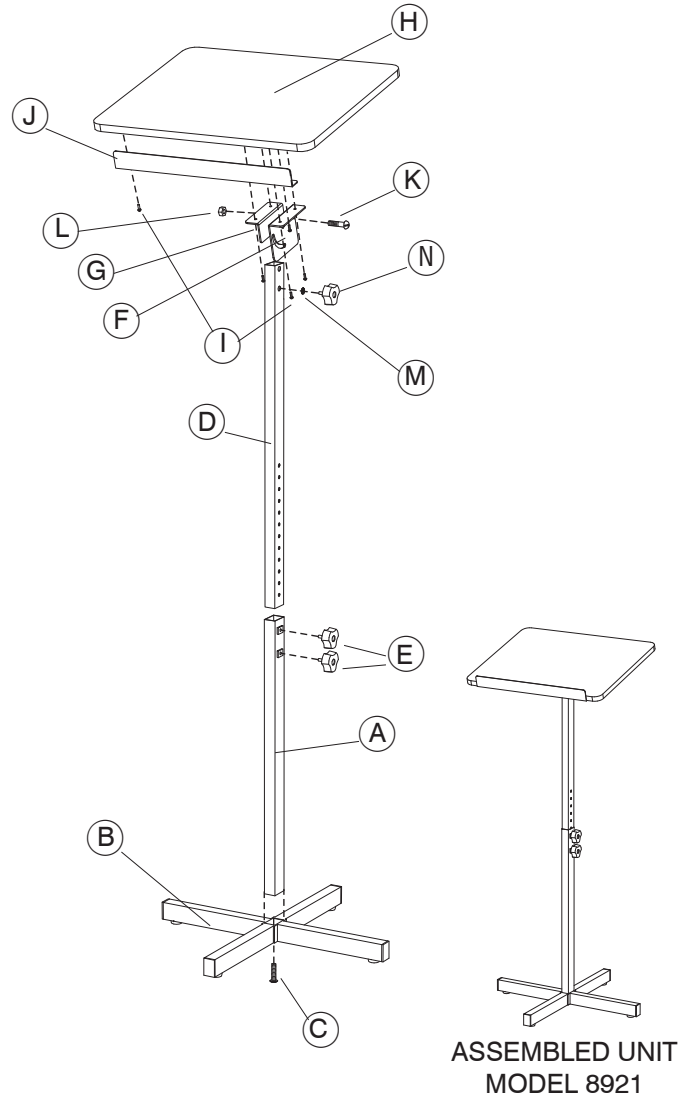

- 1** Insert the (A) Lower Post into the (B) Base and fasten with the (C) Bolt (fully threaded) from the underside of the Base.

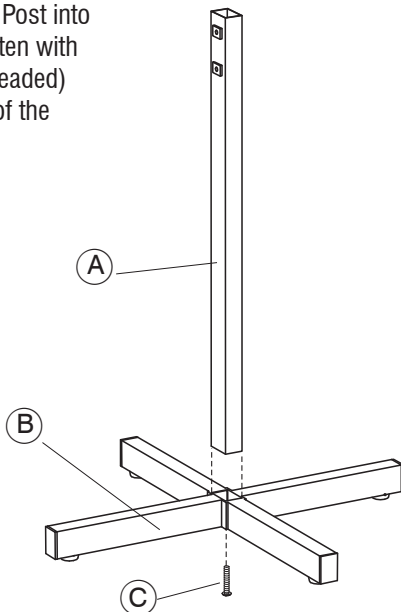

- 2** Insert the (D) Upper Post into the Lower Post, line up the holes in one post with the holes in the other post at an appropriate height, and fasten with two (E) Knobs with Long Stems.

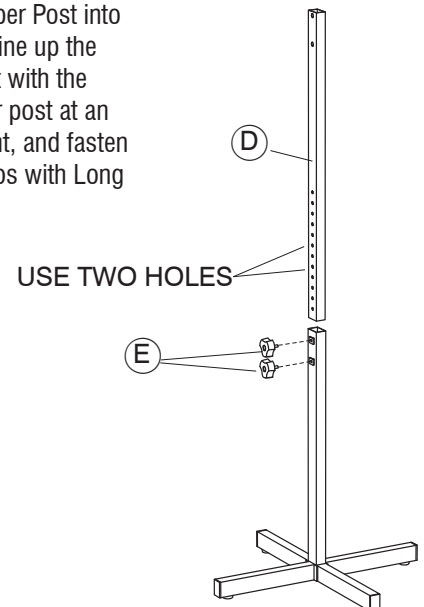

- 3** Attach the (F) Adjustment Bracket and the (G) Retaining Bracket to the (H) Top Platform, using four (I) Small Screws. Be sure that the slot of the Adjustment Bracket is facing the two small holes along the front edge of the Top Platform.

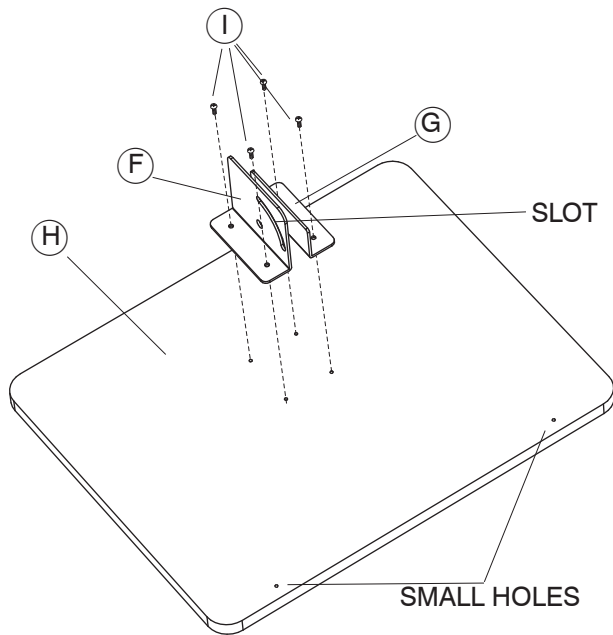

- 4** Attach the (J) Paper Stop/Pencil Ledge to the Top Platform, using the two remaining Small Screws.

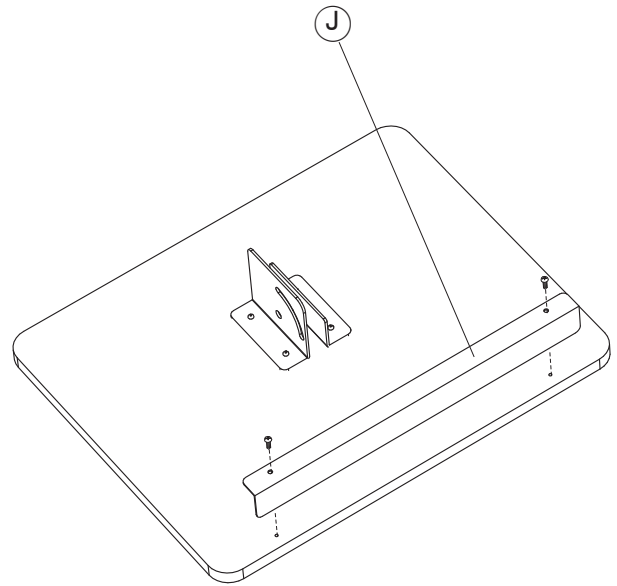

- 5** Align the hole in the Adjustment Bracket with the top hole in the Upper Post; then insert the (K) Pivot Bolt through the holes. Fasten with the (L) Nut, but do not overtighten (the Top Platform must be able to tilt freely).

Place the (M) Star Washer onto the stem of the (N) Knob with Short Stem, and screw the Knob through the slot in the Adjustment Bracket and into the hole in the Upper Post.

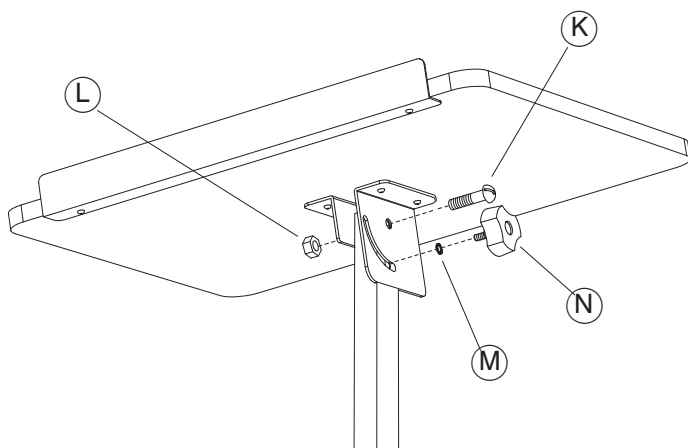

- 6** Level the unit using the levelers on the Base.

Adjust the height by removing the two Knobs, aligning the Posts to the desired height, and reinserting the Knobs.

Loosen the uppermost Knob, adjust the Top Platform angle, and retighten.

