



ARC Table 30-42"H

Adjustable Height Instructions

INS611 Rev B

Required tools

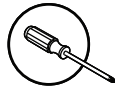

7/16"

E

- A Table Top (1X)
- B ARC Leg (2X)
- C Adjustable Leg (2X)
- D Mounting Plate (2X)
- E Wrench 7/16"
- F Locknut (10X)
- G Machine Screw (22X)
- H Wood Screw (8X)
- I Levelers (4X)

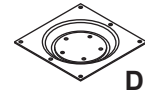

D



E



F



G



H



I

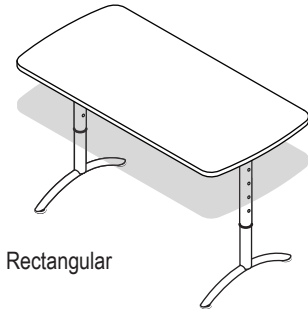

Rectangular

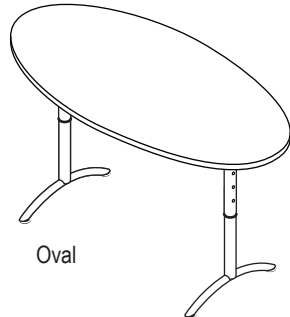

Oval

1

Attach top plates, Align holes marked with red dot

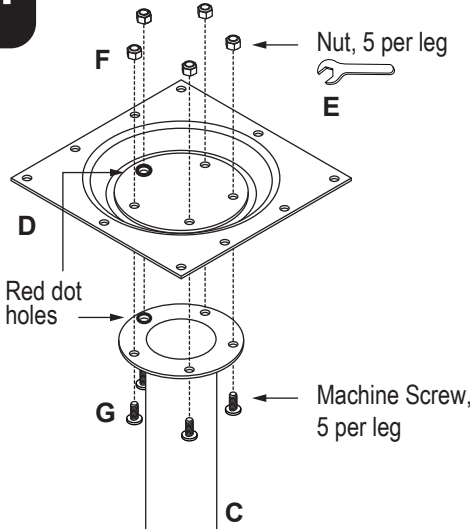

2

Attach adjustable leg and set height

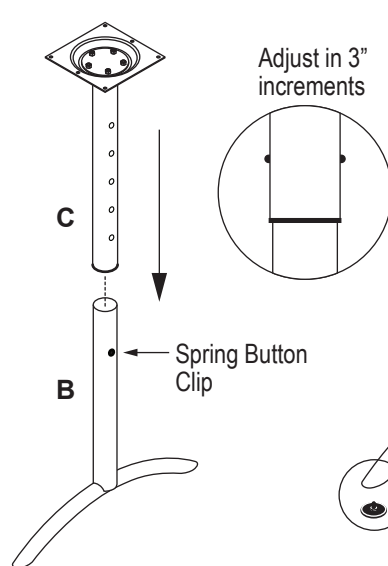

Attach levelers (4X)

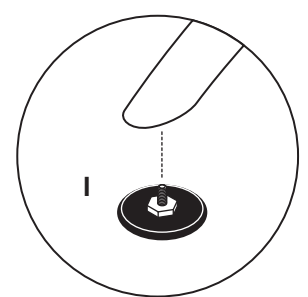

CAUTION !
Adjust legs to desired height before attaching to table top

3

Attach legs with both machine and wood screws



CAUTION !
Set tabletop upside down on protected surface

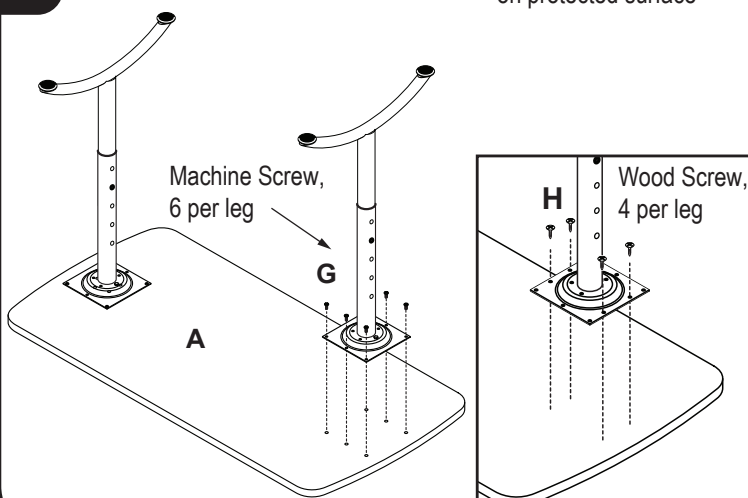

4

Set table upright

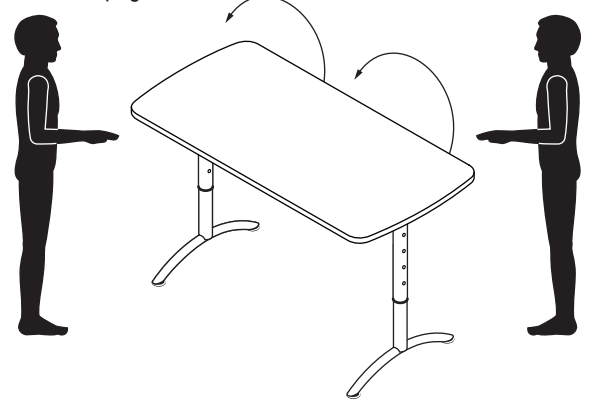

CAUTION !
2 persons required to flip table over.
Always remove items from table before adjusting height.
2 persons required to adjust both legs at the same time.