

FEATURES

• FLIP TOP ADJUSTMENT

To flip top up or down, lift either lever, flip top up or down and release lever to lock into place.

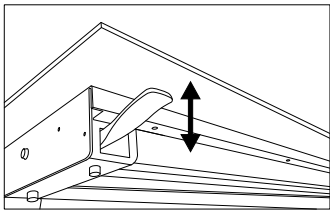

WARNING

1. Use this product for its intended purpose.
2. Do not use this table unless all screws and bolts are securely tightened.
3. Check that all screws and bolts are tight every three months or as needed.
4. Dispose of packing material properly. Do not use plastic cover as head covering. It may cause suffocation.
5. Do not use table as a stepladder.

OSP FURNITURE TRAINING TABLES LIMITED WARRANTY

OSP Training Table Series is warranted* from date of purchase against failure due to material and workmanship as follows:

- Laminate finishes are covered for a period of 5 years.
- Lifetime on component parts including control mechanism, frame and casters.

**All warranties are limited to the original purchaser for normal commercial usage defined as a standard forty hour work week. This warranty will not cover labor, freight or damage from misuse, abuse, negligence, alteration, accident, vandalism, rusting, acts of nature or any other event beyond the control of Office Star Products. The warranty does not cover cosmetic damage that may result from normal use. Liability for incidental or consequential damages is excluded. The user assumes all risk of injury resulting from use of this product. When usage is more than 40 hours per week, a two year warranty on all parts applies. This warranty gives you specific legal rights, and you may also have other rights which vary from state to state.*

Our quality standards are among the highest in the industry. Sometimes, no matter how hard we try, there are times when parts are damaged or missing. Our Parts Department will do everything possible to promptly remedy the problem. Contact us via e-mail parts@officestar.net, by Fax 1-909-930-5629, or toll free parts number 1-800-950-7262, Monday through Friday 8:00 a.m. - 5:00 p.m. Pacific Time.

84224

TRAINING TABLES

ASSEMBLY INSTRUCTIONS

STEP 1

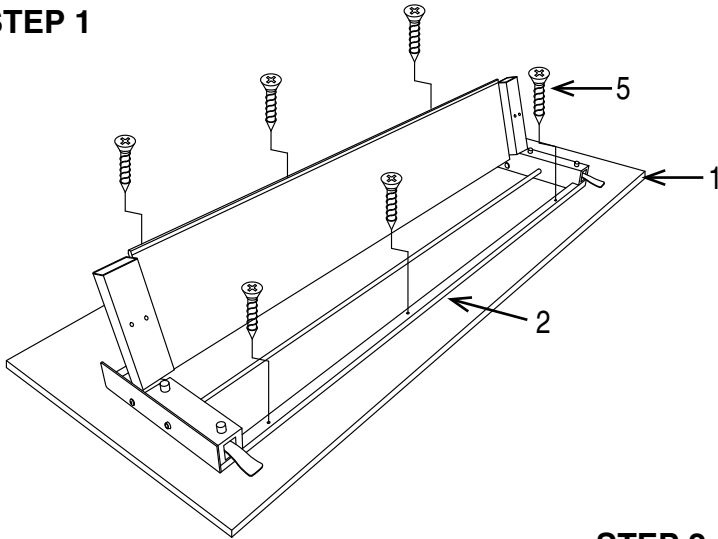

PART	QTY
1. Top	1
2. Frame	1
3. Leg Frame (3L & 3R).....	2
4. Casters	4
5. Wood Screw	6
6. Bolt w/ Washer	4
7. Allen Wrench (not shown)	1

Phillips screwdriver also needed for assembly (not provided).

STEP 2

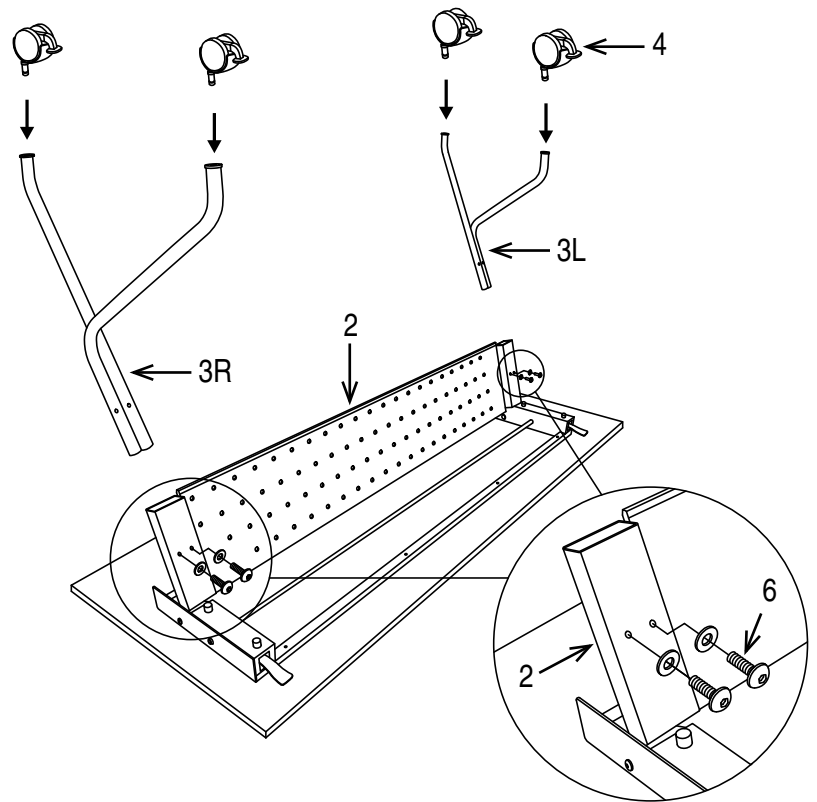

Remove all the parts from carton, separate them into part numbers indicated on the list and make sure part quantities are correct.

STEP 1 Secure Frame (2) to Top (1) using six Wood Screws (5). **FULLY TIGHTEN ALL WOOD SCREWS (5) USING PHILLIPS SCREWDRIVER (not provided).**

STEP 2 Insert Leg Frames (3L & 3R) into Frame (2) and secure using two Bolts w/ Washers (6) for each Leg Frame (3). **FULLY TIGHTEN ALL BOLTS W/ WASHERS (6) USING ALLEN WRENCH (7).** Insert two Casters (4) into each Leg Frame (3), push hard until you feel or hear the Caster (4) snap into place. **ATTENTION: MAKE SURE ALL SCREWS AND BOLTS ARE FULLY TIGHTENED BEFORE USING TABLE.**